

Prestige 310

Broadband Sharing Gateway

User's Guide

Version 2.51

Nov 2000

ZyXEL

TOTAL INTERNET ACCESS SOLUTION

Prestige 310

Broadband Sharing Gateway

Copyright

Copyright © 2000 by ZyXEL Communications Corporation.

The contents of this publication may not be reproduced in any part or as a whole, transcribed, stored in a retrieval system, translated into any language, or transmitted in any form or by any means, electronic, mechanical, magnetic, optical, chemical, photocopying, manual, or otherwise, without the prior written permission of ZyXEL Communications Corporation.

Published by ZyXEL Communications Corporation. All rights reserved.

Disclaimer

ZyXEL does not assume any liability arising out of the application or use of any products, or software described herein. Neither does it convey any license under its patent rights nor the patent rights of others. ZyXEL further reserves the right to make changes in any products described herein without notice. This publication is subject to change without notice.

Trademarks

Trademarks mentioned in this publication are used for identification purposes only and may be properties of their respective owners.

Federal Communications Commission (FCC) Interference Statement

This device complies with Part 15 of FCC rules. Operation is subject to the following two conditions:

This device may not cause harmful interference.

This device must accept any interference received, including interference that may cause undesired operations.

This equipment has been tested and found to comply with the limits for a CLASS B digital device pursuant to Part 15 of the FCC Rules. These limits are designed to provide reasonable protection against harmful interference in a commercial environment. This equipment generates, uses, and can radiate radio frequency energy, and if not installed and used in accordance with the instructions, may cause harmful interference to radio communications.

If this equipment does cause harmful interference to radio/television reception, which can be determined by turning the equipment off and on, the user is encouraged to try to correct the interference by one or more of the following measures:

Reorient or relocate the receiving antenna.

Increase the separation between the equipment and the receiver.

Connect the equipment into an outlet on a circuit different from that to which the receiver is connected.

Consult the dealer or an experienced radio/TV technician for help.

Notice 1

Changes or modifications not expressly approved by the party responsible for compliance could void the user's authority to operate the equipment.

Notice 2

Shielded RS-232 cables are required to be used to ensure compliance with FCC Part 15, and it is the responsibility of the user to provide and use shielded RS-232 cables.

Information for Canadian Users

The Industry Canada label identifies certified equipment. This certification means that the equipment meets certain telecommunications network protective, operation, and safety requirements. The Industry Canada does not guarantee that the equipment will operate to a user's satisfaction.

Before installing this equipment, users should ensure that it is permissible to be connected to the facilities of the local telecommunications company. The equipment must also be installed using an acceptable method of connection. In some cases, the company's inside wiring associated with a single line individual service may be extended by means of a certified connector assembly. The customer should be aware that the compliance with the above conditions may not prevent degradation of service in some situations.

Repairs to certified equipment should be made by an authorized Canadian maintenance facility designated by the supplier. Any repairs or alterations made by the user to this equipment, or equipment malfunctions, may give the telecommunications company cause to request the user to disconnect the equipment.

For their own protection, users should ensure that the electrical ground connections of the power utility, telephone lines, and internal metallic water pipe system, if present, are connected together. This precaution may be particularly important in rural areas.

Caution

Users should not attempt to make such connections themselves, but should contact the appropriate electrical inspection authority, or electrician, as appropriate.

Note

This digital apparatus does not exceed the class A limits for radio noise emissions from digital apparatus set out in the radio interference regulations of Industry Canada.



Declaration of Conformity

The following products is herewith confirmed to comply with the requirements set out in the Council Directive on the Approximation of the laws of the Member States relating to Electromagnetic Compatibility Directive (89/336/EEC). The listed standard as below were applied:

The following Equipment:

Product : LAN / Gateway Router
Model Number : PRESTIGE 310 / 310-S, ZyWALL 10

RFI Emission: Generic emission standard according to EN 50081-1/1992
Limit class B according to EN 55022/1998
Limits class A for harmonic current emission according to EN 61000-3-2/1995
Limitation of voltage fluctuation and flicker in low-voltage supply system according to EN 61000-3-3/1995

Immunity : Generic immunity standard according to EN 50082-1:1997/ EN 55024: 1998
Electrostatic Discharge according to EN 61000-4-2:1995
Contact Discharge: 4 kV, Air Discharge : 8 kV
Radio-frequency electromagnetic field according to EN 61000-4-3:1996
80 – 1000MHz with 1kHz AM 80% Modulation: 3V/m
Electromagnetic field from digital telephones according to ENV 50204:1995
900 ±5MHz with 200Hz rep. Frequency ,Duty Cycle 50%
Electrical fast transient/burst according to EN 61000-4-4:1995
AC/DC power supply: 1kV, Data/Signal lines : 0.5kV
Surge immunity test according to EN 61000-4-5:1995
AC/DC Line to Line: 1kV, AC/DC Line to Earth : 2kV
Immunity to conducted disturbances, Induced by radio-frequency fields: EN 61000-4-6:1996
0.15 – 80MHz with 1kHz AM 80% Modulation: 3V/m
Power frequency magnetic field immunity test according to EN 61000-4-8:1993
3A/m at frequency 50Hz
Voltage dips, short interruptions and voltage variations immunity test according to EN 61000-4-11:1994
30% Reduction @ 10ms/ 500ms, 60% Reduction @100ms, >95%Reduction @10ms/ 5000ms

The following importer/manufacture is responsible for this declaration:

Company Name **ZyXEL Communications Services GmbH.**
Company Address :Thaliastrasse 125a/2/2/4
A-1160 Wien • AUSTRIA
Telephone : Tel.: 01 / 494 86 77-0 Facsimile :
Fax: 01 / 494 86 78

Person is responsible for marking this declaration:

Manfred RECLA
Name (Full Name)
October 23, 2000
Date

ZyXEL Techn. Support
Position/ Title
Manfred Recla
Legal Signature
ZyXEL Communications Services GmbH.
Thaliastrasse 125a/2/2/4
A-1160 Wien • AUSTRIA
Tel.: 01 / 494 86 77-0
Fax: 01 / 494 86 78

Declaration of Conformity

We, the Manufacturer/Importer,

ZyXEL Communications Corp.
No. 6, Innovation Rd. II,
Science-Based Industrial Park,
Hsinchu, Taiwan, 300 R.O.C

declare that the product

Prestige 310

is in conformity with

(reference to the specification under which conformity is declared)

Standard	Standard Item	Version
• EN 55022	Radio disturbance characteristics – Limits and method of measurement.	1994
• EN 61000-3-2	Disturbance in supply system caused by household appliances and similar electrical equipment “Harmonics”.	1995
• EN 61000-3-3	Disturbance in supply system caused by household appliances and similar electrical equipment “Voltage fluctuations”.	1995
• EN 61000-4-2	Electrostatic discharge immunity test – Basic EMC Publication	1995
• EN 61000-4-3	Radiated, radio-frequency, electromagnetic field immunity test	1996
• EN 61000-4-4	Electrical fast transient / burst immunity test - Basic EMC Publication	1995
• EN 61000-4-5	Surge immunity test	1995
• EN 61000-4-6	Immunity to conducted disturbances, induced by radio-frequency fields	1996
• EN 61000-4-8		1993
• EN61000-4-11	Voltage dips, short interruptions and voltage variations immunity tests	1994

ZyXEL Limited Warranty

ZyXEL warrants to the original end user (purchaser) that this product is free from any defects in materials or workmanship for a period of up to two years from the date of purchase. During the warranty period, and upon proof of purchase, should the product have indications of failure due to faulty workmanship and/or materials, ZyXEL will, at its discretion, repair or replace the defective products or components without charge for either parts or labor, and to whatever extent it shall deem necessary to restore the product or components to proper operating condition. Any replacement will consist of a new or re-manufactured functionally equivalent product of equal value, and will be solely at the discretion of ZyXEL. This warranty shall not apply if the product is modified, misused, tampered with, damaged by an act of God, or subjected to abnormal working conditions.

Note

Repair or replacement, as provided under this warranty, is the exclusive remedy of the purchaser. This warranty is in lieu of all other warranties, express or implied, including any implied warranty of merchantability or fitness for a particular use or purpose. ZyXEL shall in no event be held liable for indirect or consequential damages of any kind of character to the purchaser.

To obtain the services of this warranty, contact ZyXEL's Service Center; refer to the separate Warranty Card for your Return Material Authorization number (RMA). Products must be returned Postage Prepaid. It is recommended that the unit be insured when shipped. Any returned products without proof of purchase or those with an out-dated warranty will be repaired or replaced (at the discretion of ZyXEL) and the customer will be billed for parts and labor. All repaired or replaced products will be shipped by ZyXEL to the corresponding return address, Postage Paid (USA and territories only). If the customer desires some other return destination beyond the U.S. borders, the customer shall bear the cost of the return shipment. This warranty gives you specific legal rights, and you may also have other rights that vary from state to state.



Please register your ZyWALL (fast, easy online registration at www.zyxel.com) for free product updates and information.

Customer Support

If you have questions about your ZyXEL product or desire assistance, contact ZyXEL Communications Corporation offices worldwide, in one of the ways listed below.

When Contacting Customer Support Representative

When you contact your customer support representative have the following information ready:

- Prestige Model and serial number
- Information in **Menu 24.2.1 –System Information**
- Warranty Information
- Date you received your Prestige
- Brief description of the problem and the steps you took to solve it.

Method \ Region	EMAIL – Support	Telephone	Web Site	Regular Mail
	EMAIL – Sales	Fax	FTP Site	
Worldwide	support@zyxel.com.tw support@europe.zyxel.com	+886-3-578-3942	www.zyxel.com www.europe.zyxel.com	ZyXEL Communications Corp., 6 Innovation Road II, Science-Based Industrial Park, HsinChu, Taiwan.
	sales@zyxel.com.tw	+886-3-578-2439	ftp.europe.zyxel.com	
North America	support@zyxel.com	+1-714-632-0882 800-255-4101	www.zyxel.com	ZyXEL Communications Inc., 1650 Miraloma Avenue, Placentia, CA 92870, U.S.A.
	sales@zyxel.com	+1-714-632-0858	ftp.zyxel.com	
Scandinavia	support@zyxel.dk	+45-3955-0700	www.zyxel.dk	ZyXEL Communications A/S, Columbusvej 5, 2860 Soeborg, Denmark.
	sales@zyxel.dk	+45-3955-0707	ftp.zyxel.dk	
Austria	support@zyxel.at	+43-1-4948677-0 0810-1-ZyXEL 0810-1-99935	www.zyxel.at	ZyXEL Communications Services GmbH., Thaliastrasse 125a/2/2/4, A-1160 Vienna, Austria
	sales@zyxel.at	+43-1-4948678	ftp.zyxel.at Note: for Austrian users with *.at domain only!	
Germany	support@zyxel.de	+49-2405-6909-0 0180-5213247 Tech Support hotline 0180-5099935 RMA/Repair hotline	www.zyxel.de	ZyXEL Deutschland GmbH., Adenauerstr. 20/A4, D-52146 Wuersele, Germany.
	sales@zyxel.de	+49-2405-6909-99	ftp.europe.zyxel.com	

Table of Contents

Copyright.....	ii
Federal Communications Commission (FCC) Interference Statement	iii
Information for Canadian Users	iv
ZyXEL Limited Warranty	viii
Customer Support.....	ix
When Contacting Customer Support Representative	ix
Table of Contents.....	xi
List of Figures	xvii
List of Tables.....	xxi
Preface	xxiii
<i>Part I:</i>	<i>I</i>
Chapter 1 : Getting to Know Your Prestige	1-1
1.1 The Prestige 310 Broadband Sharing Gateway.....	1-1
1.2 Quick Feature Overview of the Prestige 310	1-1
1.3 Detailed Features of the Prestige 310.....	1-1
1.4 Applications for Prestige 310.....	1-3
1.4.1 Broadband Internet Access via Cable or xDSL Modem	1-3
1.5 Internet Access Configuration Checklist.....	1-3
Chapter 2 : Hardware Installation & Initial Setup	2-1
2.1 Front Panel LEDs and Back Panel Ports	2-1
2.1.1 Front Panel LEDs.....	2-1
2.2 Prestige 310 Rear Panel and Connections	2-2
2.3 Additional Installation Requirements.....	2-3
2.4 Power Up Your Prestige.....	2-4
2.5 Navigating the SMT Interface.....	2-5
2.5.1 Main Menu	2-6
2.5.2 System Management Terminal Interface Summary	2-6

2.6	Changing the System Password	2-7
2.6.1	Resetting the Prestige.....	2-7
2.7	General Setup.....	2-8
2.7.1	Dynamic DNS.....	2-8
2.7.2	Configuring Dynamic DNS.....	2-9
2.8	WAN Setup.....	2-10
2.9	LAN Setup	2-11
2.9.1	LAN Port Filter Setup	2-12
Chapter 3	: Internet Access.....	3-1
3.1	TCP/IP and DHCP for LAN	3-1
3.1.1	Factory LAN Defaults.....	3-1
3.1.2	IP Address and Subnet Mask	3-1
3.1.3	Private IP Addresses	3-2
3.1.4	RIP Setup	3-2
3.1.5	DHCP Configuration.....	3-3
3.1.6	IP Multicast.....	3-3
3.1.7	IP Alias	3-4
3.2	TCP/IP and DHCP Ethernet Setup.....	3-4
3.2.1	IP Alias Setup	3-7
3.3	Internet Access Setup.....	3-8
3.3.1	Ethernet Encapsulation	3-8
3.3.2	PPTP Encapsulation.....	3-10
3.3.3	Configure PPTP Client.....	3-11
3.3.4	PPPoE Encapsulation.....	3-11
3.4	Internet Test Setup	3-13
3.5	Basic Setup Complete	3-13
<i>Part II:</i>		<i>II</i>
Chapter 4	: SUA and Multiple SUA Servers	4-1
4.1	Single User Account (SUA).....	4-1
4.1.1	Basics	4-1
4.1.2	Single User Account Configuration	4-2
4.2	Multiple Servers behind SUA	4-3
4.2.1	Configuring a Server behind SUA	4-3
Chapter 5	Remote Node Setup	5-1

5.1	Remote Node Profile.....	5-1
5.1.1	Ethernet Encapsulation.....	5-1
5.1.2	PPTP Encapsulation.....	5-3
5.1.3	PPPoE Encapsulation.....	5-4
5.2	Editing TCP/IP Options (with Ethernet Encapsulation).....	5-6
5.2.1	Editing TCP/IP Options (with PPTP Encapsulation).....	5-7
5.2.2	Editing TCP/IP Options (with PPPoE Encapsulation).....	5-9
5.3	Remote Node Filter.....	5-10
Chapter 6 : IP Static Route Setup.....		6-1
6.1	IP Static Route Setup.....	6-2
<i>Part III:</i>		<i>III</i>
Chapter 7 : Filter Configuration.....		7-1
7.1	About Filtering.....	7-1
7.1.1	The Filter Structure of the Prestige.....	7-2
7.2	Configuring a Filter Set.....	7-4
7.2.1	Filter Rules Summary Menu.....	7-6
7.2.2	Configuring a Filter Rule.....	7-7
7.2.3	TCP/IP Filter Rule.....	7-7
7.2.4	Generic Filter Rule.....	7-12
7.3	Example Filter.....	7-14
7.3.1	Before you begin.....	7-14
7.3.2	Filter Configuration Steps.....	7-14
7.4	Filter Types and SUA.....	7-17
7.5	Applying a Filter and Factory Defaults.....	7-18
7.5.1	LAN traffic.....	7-18
7.5.2	Remote Node Filters.....	7-18
Chapter 8 : SNMP Configuration.....		8-1
8.1	SNMP.....	8-1
8.1.1	SNMP Configuration.....	8-2
Chapter 9 : System Information & Diagnosis.....		9-1
9.1	System Status.....	9-2
9.2	System Information and Console Port Speed.....	9-4
9.2.1	System Information.....	9-4

9.2.2	Console Port Speed	9-5
9.3	Log and Trace	9-5
9.3.1	Viewing Error Log	9-6
9.3.2	UNIX Syslog.....	9-6
9.3.3	Call-Triggering Packet	9-10
9.4	Diagnostic	9-11
9.4.1	WAN DHCP	9-11
Chapter 10 :	Transferring Files	10-1
10.1	Filename conventions	10-1
10.1.1	Firmware Development.....	10-2
10.2	Backup Configuration.....	10-2
10.3	Restore Configuration.....	10-4
10.4	Upload Firmware	10-5
10.4.1	Upload Router Firmware via the Console Port	10-6
10.4.2	Upload Router Firmware using FTP	10-6
1.1.1	Example - Using the FTP command from the DOS Prompt	10-7
1.1.1	Upload Router Firmware using TFTP.....	10-8
1.1.2	Example Using TFTP To Upload Prestige Firmware	10-9
1.2	Upload Router Configuration File	10-9
1.2.1	Upload Router Configuration File using the Console Port	10-9
1.2.2	Upload Router Configuration File using FTP.....	10-10
1.2.3	Upload Router Configuration File using TFTP.....	10-11
Chapter 11 :	System Maintenance & Information.....	11-1
11.1	Command Interpreter Mode.....	11-1
11.2	Call Control Support	11-1
11.2.1	Budget Management	11-2
11.2.2	Call History.....	11-3
11.3	Time and Date Setting	11-4
11.4	Boot commands	11-6
Chapter 12 :	Call Schedule Setup	12-1
12.1.1	Applying A Schedule Set.....	12-3
Chapter 13 :	Telnet Configuration and Capabilities	13-1
13.1	About Telnet Configuration.....	13-1

13.2	Telnet Under SUA.....	13-1
13.3	Telnet Capabilities	13-1
13.3.1	Single Administrator	13-1
13.3.2	System Timeout.....	13-2
<i>Part IV:</i>		<i>IV</i>
Chapter 14 : Troubleshooting		14-1
14.1	Problems Starting Up the Prestige.....	14-1
14.2	Problems with the LAN Interface	14-2
14.3	Problems with the WAN interface	14-2
14.4	Problem with Remote Node or ISP Connection.....	14-3
14.5	Problems with Internet Access	14-3
14.6	General Instructions	14-3
Appendix A: PPTP		E
What is PPTP?.....		E
How can we transport PPP frames from a PC to a broadband modem over Ethernet?		E
PPTP and the Prestige		E
PPTP Protocol Overview.....		E
Control & PPP connections		F
Appendix B: PPPoE.....		G
Appendix C: Hardware Specifications		I
Appendix D: Important Safety Instructions		K
Glossary of Terms.....		L
Index		S

List of Figures

Figure 1-1	Internet Access Application	1-3
Figure 2-1	Front Panel	2-1
Figure 2-2	Prestige 310 Rear Panel and Connections	2-2
Figure 2-3	Initial Screen	2-4
Figure 2-4	Password Screen.....	2-5
Figure 2-5	Prestige 310 Main Menu	2-6
Figure 2-6	Menu 23 - System Security	2-7
Figure 2-7	Menu 1 – General Setup.....	2-9
Figure 2-8	Configure Dynamic DNS	2-10
Figure 2-9	Menu 2 – WAN Setup	2-11
Figure 2-10	Menu 3 - LAN Setup.....	2-12
Figure 2-11	Menu 3.1 – LAN Port Filter Setup	2-12
Figure 3-1	Physical Network	3-4
Figure 3-2	Partitioned Logical Networks.....	3-4
Figure 3-3	Menu 3 - LAN Setup (10/100 Mbps Ethernet).....	3-5
Figure 3-4	Menu 3.2 – TCP/IP and DHCP Ethernet Setup.....	3-5
Figure 3-5	Menu 3.2.1 - IP Alias Setup	3-7
Figure 3-6	Internet Access Setup (Ethernet).....	3-8
Figure 3-7	Internet Access Setup (PPTP)	3-11
Figure 3-8	Internet Access (PPPoE)	3-12
Figure 3-9	Internet Setup Test Example.....	3-13
Figure 4-1	An Example of Single User Account Topology	4-1
Figure 4-2	Menu 4 - Internet Access Setup for Single User Account.....	4-2
Figure 4-3	Multiple Server Configuration	4-4
Figure 5-1	Menu 11.1 Remote Node Profile for Ethernet Encapsulation	5-1

Figure 5-2	Remote Node Profile for PPTP Encapsulation	5-3
Figure 5-3	Menu 11.1 Remote Node Profile for PPPoE Encapsulation	5-5
Figure 5-4	Remote Node Network Layer Options.....	5-6
Figure 5-5	Remote Node Network Layer Options.....	5-7
Figure 5-6	Remote Node Network Layer Options.....	5-9
Figure 5-7	Remote Node Filter (Ethernet Encapsulation)	5-11
Figure 5-8	Remote Node Filter (PPTP/PPPoE Encapsulation.....	5-11
Figure 6-1	Example of Static Routing Topology	6-1
Figure 6-2	Menu 12 - IP Static Route Setup.....	6-2
Figure 6-3	Menu 12. 1 - Edit IP Static Route	6-2
Figure 7-1	Outgoing Packet Filtering Process	7-1
Figure 7-2	Filter Rule Process	7-3
Figure 7-3	Menu 21 - Filter Set Configuration.....	7-4
Figure 7-4	NetBIOS_WAN Filter Rules Summary.....	7-5
Figure 7-5	NetBIOS_LAN Filter Rules Summary	7-5
Figure 7-6	TEL_FTP_WEB_WAN Filter Rules Summary	7-5
Figure 7-7	Menu 21.1.1 - TCP/IP Filter Rule.....	7-8
Figure 7-8	Executing an IP Filter	7-11
Figure 7-9	Menu 21.4.1 - Generic Filter Rule	7-12
Figure 7-10	Filter Example.....	7-14
Figure 7-11	Example Filter - Menu 21.3.1	7-15
Figure 7-12	Example Filter Rules Summary – Menu 21.3	7-16
Figure 7-13	Example Filter Rules Summary	7-17
Figure 7-14	Protocol and Device Filter Sets.....	7-17
Figure 7-15	Filtering LAN Traffic.....	7-18
Figure 7-16	Filtering Remote Node Traffic	7-19
Figure 8-1	SNMP Management Model	8-1

Figure 8-2	Menu 22 - SNMP Configuration	8-2
Figure 9-1	Menu 24 - System Maintenance	9-1
Figure 9-2	Menu 24.1 - System Maintenance – Status	9-2
Figure 9-3	Menu 24.2 – System Information and Console Port Speed.....	9-4
Figure 9-4	Menu 24.2.1 System Maintenance - Information	9-4
Figure 9-5	Menu 24.2.2 – System Maintenance – Change Console Port Speed	9-5
Figure 9-6	Examples of Error and Information Messages	9-6
Figure 9-7	Examples of Error and Information Messages	9-6
Figure 9-8	Menu 24.3.2 - System Maintenance – UNIX Syslog	9-7
Figure 9-9	Call-Triggering Packet Example	9-10
Figure 9-10	Menu 24.4 - System Maintenance - Diagnostic	9-11
Figure 9-11	WAN & LAN DHCP	9-12
Figure 10-1	Menu 24.5 - System Maintenance - Backup Configuration (via console port)	10-3
Figure 10-2	Backup Example Using HyperTerminal	10-3
Figure 10-3	Successful Backup Confirmation Screen.....	10-3
Figure 10-4	Telnet into Menu 24.5	10-4
Figure 10-5	Menu 24.6 - System Maintenance - Restore Configuration (via console port)	10-4
Figure 10-6	Successful Restoration Confirmation Screen	10-5
Figure 10-7	Telnet into Menu 24.6	10-5
Figure 10-8	Menu 24.7 - System Maintenance - Upload Firmware.....	10-5
Figure 10-9	Menu 24.7.1 - System Maintenance - Upload Router Firmware.....	10-6
Figure 10-10	Menu 24.7.1 as seen using Telnet.....	10-7
Figure 10-11	FTP Session Example	10-7
Figure 10-12	Menu 24.7.2 as seen using the Console Port	10-10
Figure 10-13	Menu 24.7.2 as seen using Telnet.....	10-11
Figure 11-1	Command Mode.....	11-1
Figure 11-2	Call Control.....	11-2

Figure 11-3	Budget Management	11-2
Figure 11-4	Call History	11-3
Figure 11-5	System Maintenance – Time and Date Setting.....	11-5
Figure 11-6	Boot Module Commands	11-6
Figure 12-1	Schedule Setup	12-1
Figure 12-2	Schedule Set Setup	12-2
Figure 12-3	Applying Schedule Set(s) to A Remote Node.....	12-4
Figure 13-1	Telnet Configuration on a TCP/IP Network.....	13-1

List of Tables

Table 1-1	Internet Access Configuration Checklist.....	1-4
Table 2-1	LED functions	2-1
Table 2-2	Terminal Emulation Software	2-4
Table 2-3	Main Menu Commands.....	2-5
Table 2-4	Main Menu Summary.....	2-6
Table 2-5	General Setup Menu Field	2-9
Table 2-6	Configure Dynamic DNS Menu Fields	2-10
Table 2-7	WAN Setup Menu Fields.....	2-11
Table 3-1	LAN DHCP Setup Menu Fields.....	3-6
Table 3-2	LAN TCP/IP Setup Menu Fields	3-6
Table 3-3	IP Alias Setup Menu Fields.....	3-7
Table 3-4	Internet Access Setup Menu Fields	3-10
Table 3-5	New Fields in Menu 4 (PPTP) screen	3-11
Table 3-6	New Fields in Menu 4 (PPPoE) screen	3-12
Table 4-1	Single User Account Menu Fields.....	4-2
Table 4-2	Services vs. Port number.....	4-4
Table 5-1	Fields in Menu 11.1 (Ethernet Encapsulation)	5-2
Table 5-2	Fields in Menu 11.1 (PPTP Encapsulation).....	5-3
Table 5-3	Fields in Menu 11.1 (PPPoE Encapsulation Specific Only).....	5-5
Table 5-4	Remote Node Network Layer Options Menu Fields	5-6
Table 5-5	Remote Node Network Layer Options Menu Fields	5-8
Table 5-6	Remote Node Network Layer Options Menu Fields	5-9
Table 6-1	IP Static Route Menu Fields.....	6-3
Table 7-1	Abbreviations Used in the Filter Rules Summary Menu.....	7-6
Table 7-2	Abbreviations Used If Filter Type Is IP	7-7

Table 7-3	Abbreviations Used If Filter Type Is GEN.....	7-7
Table 7-4	TCP/IP Filter Rule Menu Fields	7-8
Table 7-5	Generic Filter Rule Menu Fields.....	7-13
Table 8-1	SNMP Configuration Menu Fields	8-3
Table 9-1	System Maintenance - Status Menu Fields	9-3
Table 9-2	Fields in System Maintenance	9-5
Table 9-3	System Maintenance Menu Syslog Parameters	9-7
Table 9-4	System Maintenance Menu Diagnostic.....	9-12
Table 10-1	Filename Conventions.....	10-2
Table 10-2	Third Party FTP Clients –General fields.....	10-7
Table 10-3	Third Party TFTP Clients –General fields	10-9
Table 11-1	Budget Management	11-3
Table 11-2	Call History Fields	11-4
Table 11-3	Time and Date Setting Fields	11-5
Table 12-1	Schedule Set Setup Fields.....	12-3
Table 14-1	Troubleshooting the Start-Up of your Prestige	14-1
Table 14-2	Troubleshooting the LAN Interface	14-2
Table 14-3	Troubleshooting the WAN interface	14-2
Table 14-4	Remote Node or ISP Connection	14-3
Table 14-5	Internet Access.....	14-3

Preface

About Your Gateway

Congratulations on your purchase of the Prestige 310 Broadband Sharing Gateway. Don't forget to register your Prestige (fast, easy online registration at www.zyxel.com) for free future product updates and information.

The Prestige 310 is a dual Ethernet broadband gateway integrated with network management features that allows access to the Internet via Cable/xDSL modem. It is designed for:

- Home offices and small businesses with Cable and xDSL modem via Ethernet port as Internet access media.
- Multiple office/department connections via access devices.

Your Prestige 310 is easy to install and to configure. The embedded web configurator is a convenient platform-independent GUI (Graphical User Interface) that allows you to access the Prestige's management settings.

All functions of the Prestige 310 are also software configurable via the SMT (System Management Terminal) interface. The SMT is a menu-driven interface that you can access from a terminal emulator through the console port or over a telnet connection.

About This User's Manual

This manual is designed to guide you through the SMT configuration of your Prestige 310 for its various applications.

Structure of this Manual

This manual is structured as follows:

- Part I. *Getting Started* (Chapters 1-3) is structured as a step-by-step guide to help you connect, install and setup your Prestige to operate on your network and access the Internet.
- Part II. *Advanced Applications* (Chapters 4-6) describe the advanced applications of your Prestige, such as Multiple SUA Server Setup, Remote Node Setup and IP Static routes.
- Part III. *Advanced Management* (Chapter 7 - 13) Chapters 7 - 13 provide information on Prestige Filtering, System Information and Diagnosis, SNMP configuration, Upgrading Software and Telnet.
- Part IV. *Troubleshooting* (Chapter 14), provides information about solving common problems as well as some Appendices.

Regardless of your particular application, it is important that you follow the steps outlined in *Chapters 1-2* to connect your Prestige to your LAN. You can then refer to the appropriate chapters of the manual, depending on your applications.

Related Documentation

➤ Supporting CD

More detailed information about the Prestige and examples of its use can be found in our Supporting CD. This CD contains HTML help on the Web Embedded Configurator, our handy web-based Internet access wizard designed to get you up and running as soon as possible, the Prestige 310 manual in PDF format,

Support Notes (that include a General FAQ, an Advanced FAQ, Applications Notes, Troubleshooting, Reference CI Commands) and bundled software.

➤ Read Me First

Our Read Me First is designed to help you get your Prestige up and running right away. It contains a detailed easy to follow connection diagram, Prestige default settings, handy checklists and information on setting up your PC.

➤ Packing List Card

Finally, you should have a Packing List Card that lists all items that should have come with your Prestige..

➤ ZyXEL Web Page and FTP Server Site

You can access release notes for firmware upgrades and other information at ZyXEL web pages and FTP server sites. Refer to the Customer Support page in this User's Guide for more information.

Syntax Conventions

- “Enter” means for you to type one or more characters and press the carriage return. “Select” or “Choose” means for you to select one from the predefined choices.
- The SMT menu titles and labels are in **Bold Times** font. The choices of a menu item are in **Bold Arial** font. A single keystroke is in Arial font and enclosed in square brackets, for instance, [ENTER] means the Enter, or carriage return, key; [ESC] means the Escape Key.
- For brevity's sake, we will use “e.g.” as a shorthand for “for instance” and “i.e.” for “that is” or “in other words” throughout this manual.

Part I:

Getting Started

Chapters 1-3 are structured as a step-by-step guide to help you connect, install and setup your Prestige to operate on your network and access the Internet.

Chapter 1: Getting to Know Your Prestige

This chapter introduces the main features and applications of the Prestige as well as a checklist for fast Internet access.

1.1 The Prestige 310 Broadband Sharing Gateway

The Prestige 310 is a dual Ethernet broadband gateway integrated with robust network management features for Internet access via external Cable/xDSL modem. Equipped with 10Mbps Ethernet WAN port for WAN, an auto-negotiating 10/100Mbps Ethernet port for LAN and the Single User Account (SUA) feature, the Prestige is uniquely suited as a broadband Internet access sharing gateway for small offices and home offices.

1.2 Quick Feature Overview of the Prestige 310

- 10Mbps Ethernet for cable or xDSL modem connection.
- Auto-negotiating 10/100Mbps Ethernet.
- IP protocol routing.
- SUA/ NAT (Network Address Translation) enables multiple users to share a single ISP account, thereby accessing the Internet for the cost of a single IP address.
- Packet filtering for controlled access to and from your network.
- DHCP Server and Client Support.
- PPPoE and PPTP Support.
- Enhanced call management using Call Scheduling and Call Control.
- IP Multicast Support.
- IP Alias
- Dynamic DNS Support.
- Time Warner's RoadRunner Service support.
- Time and Date Setting support.
- Easy network management via console port, Telnet, TFTP, FTP, SNMP and CI mode.
- Built-in message logging and packet tracing and Unix syslog facility support.
- Embedded FTP server for faster firmware upgrade and backup and restoration of configuration file.
- Management via console or Telnet.
- File transfer via console port or use TFTP or FTP.

1.3 Detailed Features of the Prestige 310

DHCP Support

DHCP (Dynamic Host Configuration Protocol) allows the individual clients (workstations) to obtain the TCP/IP configuration at start-up from a centralized DHCP server. The Prestige has built-in DHCP server capability, enabled by default, which means it can assign IP addresses, an IP default gateway and DNS servers to Windows 9X, Windows NT and other systems that support the DHCP client. The Prestige can now also act as a surrogate DHCP server (DHCP Relay) where it relays IP address assignment from the actual real DHCP server to the clients.

Dynamic DNS Support

With Dynamic DNS support, you can have a static hostname alias for a dynamic IP address, allowing the host to be more easily accessible from various locations on the Internet.

If you want to utilize this service, you must register for this service with a Dynamic DNS client.

PPPoE Support

PPPoE facilitates the interaction of a host with a broadband modem to achieve access to high-speed data networks via a familiar "dial-up networking" user interface.

PPTP Support

Point-to-Point Tunneling Protocol (PPTP) is a network protocol that enables secure transfer of data from a remote client to a private server, creating a Virtual Private Network (VPN) using TCP/IP-based networks. PPTP supports on-demand, multi-protocol, and virtual private networking over public networks, such as the Internet.

IP Alias

The ability to partition physical network into logical network over the same Ethernet interface is referred to as IP Alias functionality.

Call Scheduling

The Call Scheduling feature allows you to manage a remote node. You can dictate when a remote node should be called and for how long.

Call Control

The Prestige provides budget management for outgoing calls and chronicles incoming and outgoing calls.

Full Network Management

Your Prestige offers you a variety of options for network management. It supports password protected local and remote network management via the console port or a telnet connection using SMT (System Management Interface). It also supports FTP (File Transfer Protocol) server for remote management, TFTP (Trivial FTP), SNMP (Simple Network Management Protocol) and CI (Command Interpreter) mode.

Time and Date Setting

This new feature (**Menu 24.10**) allows you to get the current time and date from an external server when you power up your Prestige. The real time is then displayed in the Prestige **Menu 24.1- System Status** and error logs. If you do not choose a time service protocol that your timeserver will send when the Prestige powers up

you can enter the time manually but each time the system is booted, the time & date will be reset to **1/1/1970 0:0:0**.

1.4 Applications for Prestige 310

1.4.1 Broadband Internet Access via Cable or xDSL Modem

The Prestige is the ideal high-speed Internet access solution for small offices and home offices. Your Prestige supports the TCP/IP protocol, which is used by the Internet exclusively. A cable modem or xDSL modem can connect to the Prestige 310 for broadband Internet access via Ethernet port on the modem. A typical Internet access application is shown next.

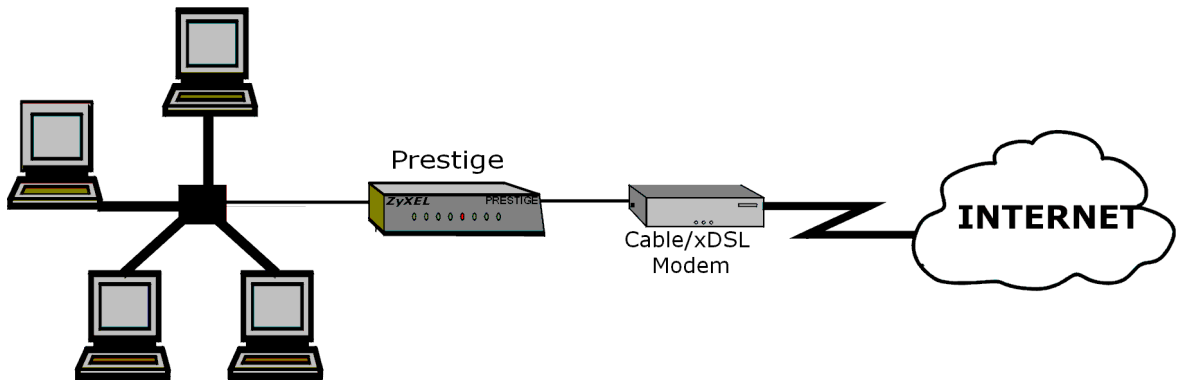

Figure 1-1 Internet Access Application

1.5 Internet Access Configuration Checklist

The following table shows the minimum SMT menu configurations you'll need to make (without changing the default Prestige values) in order to access the Internet. Please also refer to the Supporting CD which contains HTML help on the Web Embedded Configurator, our handy web-based Internet access wizard designed to get you up and running as soon as possible.

Table 1-1 Internet Access Configuration Checklist

SMT Menu	Field	Action
1	System Name	This field is for identification purposes but because some ISPs check this name you should enter your PC's "Computer Name" Click Start -> Settings -> Control Panel -> Network. Click the Identification tab, note the entry for the Computer name" field and enter it as the System Name .
2	MAC Address: Assigned By	The default is Factory Default , which is the factory assigned default MAC Address. We recommend you choose IP Address attached on LAN and enter the IP address of the workstation on the LAN whose MAC you are cloning.
4	Encapsulation PPTP PPPoE	Choose PPPoE if you have a dial-up connection to the Internet (or PPTP if you reside in France or Austria ¹); otherwise choose Ethernet . Choose from RR-Manager or RR-Toshiba if your ISP is Time Warner's RoadRunner; otherwise choose Standard . PPTP You need to know your login name, password and connection ID/Name. The latter may not be obligatory for some ISPs, but if it is you must follow the "c:id" and "n:name" format. PPPoE You need to know your login name, password and service name. The latter may not be obligatory for some ISPs.
	IP Address Assignment	If your ISP did not assign you a fixed IP address, select Dynamic , otherwise select Static and enter the IP address & subnet mask in the IP address and IP Subnet Mask fields.
Once these key fields have been configured, you should be able to enjoy super-fast Internet access with your Prestige!		

¹ PPTP only supported in France and Austria at time of writing

Chapter 2: Hardware Installation & Initial Setup

This chapter shows you how to connect the hardware and perform the initial setup.

2.1 Front Panel LEDs and Back Panel Ports

2.1.1 Front Panel LEDs

The LEDs on the front panel indicate the operational status of the Prestige.

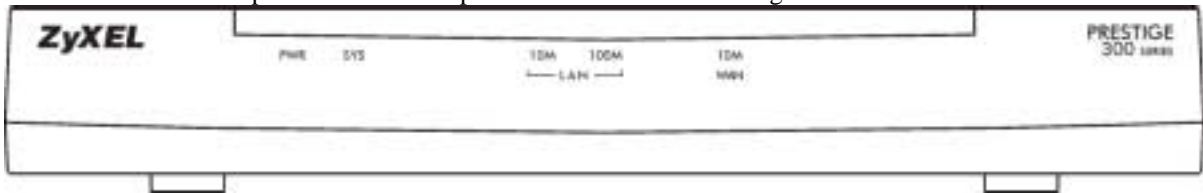

Figure 2-1 Front Panel

The following table describes the LED functions:

Table 2-1 LED functions

LEDs	Function	Indicator Status	Active	Description
PWR	Power	Green	On	The power adapter is connected to the Prestige.
SYS	System		Off	The system is not ready or failed.
			On	The system is ready and running.
			Flashing	The system is rebooting.
10M LAN	LAN	Green	Off	The 10M LAN is not connected.
			On	The Prestige is connected to a 10M LAN.
			Flashing	The 10M LAN is sending/receiving packets.
100M LAN		Orange	Off	The 100M LAN is not connected.
			On	The Prestige is connected to a 100Mbps LAN.
			Flashing	The 100M LAN is sending/receiving packets.

LEDs	Function	Indicator Status	Active	Description
WAN	WAN	Green	Off	The WAN Link is not ready, or has failed.
			On	The WAN Link is ok.
			Flashing	The 10M WAN link is sending/receiving packets.

2.2 Prestige 310 Rear Panel and Connections

The figure below shows the rear panel of your Prestige 310 and the connection diagram.

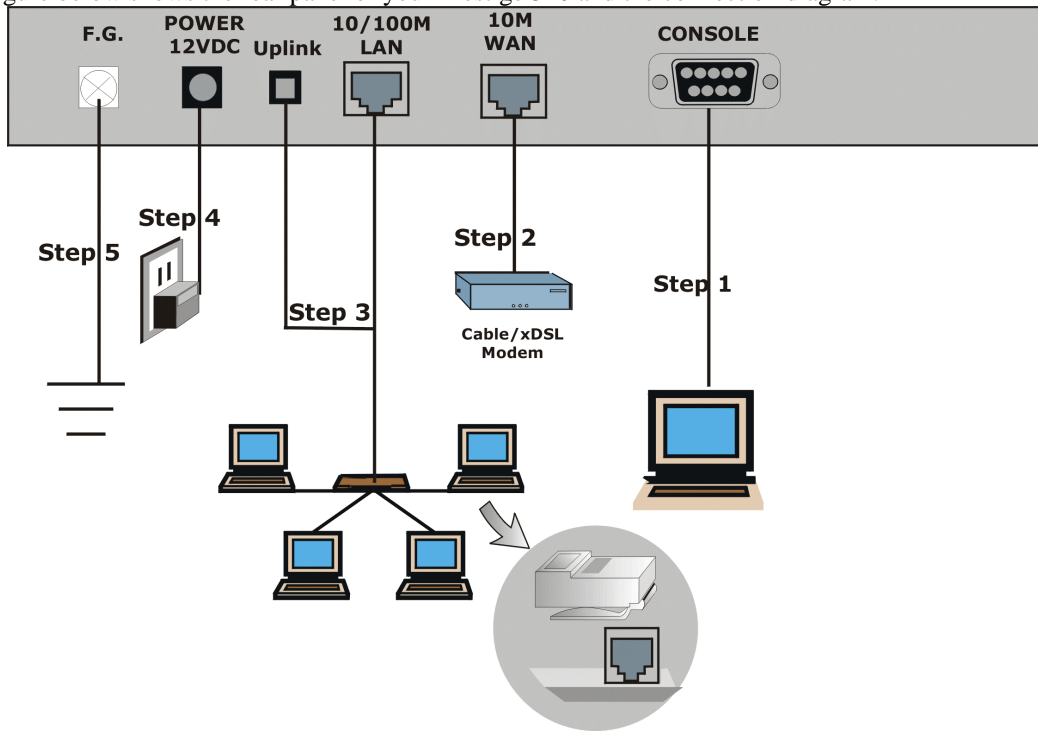

Figure 2-2 Prestige 310 Rear Panel and Connections

This section outlines how to connect your Prestige 310 to the LAN and the WAN. In the case of connecting a Cable Modem you must connect the coaxial cable from your cable service to the threaded coaxial cable connector on the back of the cable modem. Connect an xDSL Modem to the xDSL Wall Jack. Please also see *Appendix C* for important safety instructions on making connections to the Prestige.

Step 1. Connecting the Console Port

For the initial configuration of your Prestige, you need to use terminal emulator software on a workstation and connect it to the Prestige through the console port. Connect the 9-pin (smaller) end of the console cable to the console port of the Prestige and the 25-pin (bigger) end to a serial port (COM1, COM2 or other COM port) of your workstation. You can use an extension RS-232 cable if the enclosed one is too short. After the initial setup, you can modify the configuration remotely through telnet connections.

Step 2. Connecting the Prestige to the Broadband Modem

Please use the cable supplied with your broadband modem to connect the broadband modem and the Prestige.

Step 2a. Connecting the Prestige to the Cable Modem

Connect the WAN port (silver) on the Prestige to the Ethernet port on the cable modem using a straight through Ethernet cable. The Ethernet port on the cable modem is sometimes labeled "PC" or "Workstation".

OR

Step 2b. Connecting the Prestige to the xDSL Modem

Connect the WAN port (silver) on the Prestige to the Ethernet port on the xDSL modem using a straight through Ethernet cable.

Step 3. Connecting the Prestige to the LAN

When the Prestige Ethernet cable is correctly connected to the PC or hub, the front panel LAN will go on.

To connect to a single PC, connect the 10/100M LAN port on the Prestige to the Network Adapter on the PC using the white straight through cable and depress the Uplink button ("on"). If you do not depress the Uplink button, you must use a crossover cable for this connection. If you have more than one PC, you must use an external hub. Connect the 10/100M LAN port (gold) on the Prestige to a port on the hub using a straight through Ethernet cable and make sure the Uplink button is *not* depressed ("on").

Step 4. Connecting the Power Adapter to your Prestige

Connect the power adapter to the port labeled **POWER** on the rear panel of your Prestige.

Step 5. Grounding the Prestige (Optional)

Ground the Prestige by connecting a grounded wire to the **F.G.** (Frame Ground) of the Prestige.

2.3 Additional Installation Requirements

In addition to the contents of your package, there are other hardware and software requirements you need before you can install and use your Prestige. These requirements include:

1. A computer with an Ethernet NIC (Network Interface Card) installed.
2. A computer equipped with communications software called terminal emulation software configured to the following parameters:
 - ◆ VT100 terminal emulation.
 - ◆ 9600 Baud.

- ◆ No parity, 8 Data bits, 1 Stop bit, Flow Control set to None.

3. A cable/xDSL modem and an ISP account.

The following table lists some common names for the communications software, based on the type of computer you are using.

Table 2-2 Terminal Emulation Software

Operating System	Software
Windows 95/98 or Windows NT	HyperTerminal (bundled with Windows software)
Windows 3.1	Terminal (bundled with Windows software)
Macintosh	ProComm, VersaTerm (supplied separately)

After the Prestige is properly set up, you can make future changes to the configuration through telnet connections.

2.4 Power Up Your Prestige

At this point, you should have connected the console port, the LAN port, the WAN port and the power port to the appropriate devices or lines. Plug the power adapter into a wall outlet. The Power LED should be on. The SYS LED will come on after the system tests are complete. The WAN LED and one of the LAN LEDs come on immediately after the SYS LED comes on, if connections have been made to the LAN and WAN ports.

Initial Screen

When you power on your Prestige, it performs several internal tests as well as line initialization.

After the tests, the Prestige asks you to press **[Enter]** to continue, as shown.

```
Copyright (c) 1994 - 2000 ZyXEL Communications Corp.  
initialize ch =0, ethernet address: 00:a0:c5:41:51:61  
initialize ch =1, ethernet address: 00:a0:c5:41:51:62  
Press ENTER to continue...
```

Figure 2-3 Initial Screen

Entering Password

The login screen appears after you press **[Enter]**, prompting you to enter the password, as shown below.

For your first login, enter the default password **1234**. As you type the password, the screen displays an (X) for each character you type.

Please note that if there is no activity for longer than 5 minutes after you log in, your Prestige will automatically log you out and will display a blank screen. If you see a blank screen, press **[Enter]** to bring up the login screen again.

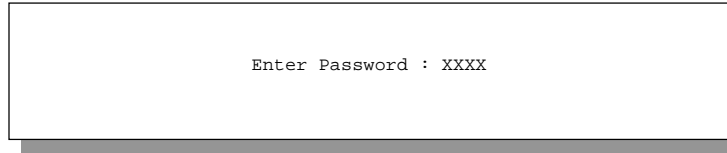

Figure 2-4 Password Screen

2.5 Navigating the SMT Interface

The SMT (System Management Terminal) is the interface that you use to configure your Prestige. Several operations that you should be familiar with before you attempt to modify the configuration are listed in the table below.

Table 2-3 Main Menu Commands

Operation	Keystroke	Description
Move down to another menu	[ENTER]	To move forward to a submenu, type in the number of the desired submenu and press [ENTER].
Move up to a previous menu	[Esc]	Press the [Esc] key to move back to the previous menu.
Move to a “hidden” menu	Press the [SPACE BAR] to change No to Yes then press [ENTER].	Fields beginning with “Edit” lead to hidden menus and have a default setting of No. Press the [SPACE BAR] to change No to Yes, then press [ENTER] to go to a “hidden” menu.
Move the cursor	[ENTER] or [Up]/[Down] arrow keys	Within a menu, press [ENTER] to move to the next field. You can also use the [Up]/[Down] arrow keys to move to the previous and the next field, respectively.
Enter information	Fill in, or Press the [SPACE BAR] to toggle	You need to fill in two types of fields. The first requires you to type in the appropriate information. The second allows you to cycle through the available choices by pressing the [Space] bar.
Required fields	<? >	All fields with the symbol <?> must be filled in order be able to save the new configuration.
N/A fields	<N/A>	Some of the fields in the SMT will show a <N/A>. This symbol refers to an option that is Not Applicable.
Save your configuration	[ENTER]	Save your configuration by pressing [ENTER] at the message [Press ENTER to confirm or ESC to cancel]. Saving the data on the screen will take you, in most cases to the previous menu.

Operation	Keystroke	Description
Exit the SMT	Type 99, then press [ENTER].	Type 99 at the Main Menu prompt and press [ENTER] to exit the SMT interface.

2.5.1 Main Menu

After you enter the password, the SMT displays the **Prestige 310 Main Menu**, as shown next.

```

Copyright (c) 1994 - 2000 ZyXEL Communications Corp.

Prestige 310 Main Menu
Getting Started          Advanced Management
 1. General Setup       21. Filter Set Configuration
 2. WAN Setup           22. SNMP Configuration
 3. LAN Setup           23. System Password
 4. Internet Access Setup 24. System Maintenance

Advanced Applications    26. Schedule Setup
 11. Remote Node Setup
 12. Static Routing Setup
 15. SUA Server Setup

                        99. Exit

Enter Menu Selection Number:
    
```

Figure 2-5 Prestige 310 Main Menu

2.5.2 System Management Terminal Interface Summary

Table 2-4 Main Menu Summary

#	Menu Title	Description
1	General Setup	Use this menu to setup general information.
2	WAN Setup	Use this menu to setup the WAN.
3	LAN Setup	Use this menu to setup the LAN.
4	Internet Access Setup	A quick and easy way to setup Internet connection.
11	Remote Node Setup	Use this menu to setup the remote node for LAN-to-LAN connection, including Internet connection.
12	Static Routing Setup	Use this menu to setup static route.
15	SUA Setup	Use this menu to specify inside servers when SUA is enabled.

#	Menu Title	Description
21	Filter Set Configuration	Use this menu to setup filters to provide security.
22	SNMP Configuration	Use this menu to setup SNMP related parameters
23	System Password	Use this menu to setup a new password.
24	System Maintenance	This menu provides system status, diagnostics, firmware upload, etc.
26	Schedule Setup	Use this menu to schedule outgoing calls.
99	Exit	To exit from SMT and return to the blank screen.

2.6 Changing the System Password

The first thing you should do before anything else is to change the default system password by following the steps below.

Step 1. Enter 23 in the Main Menu to open **Menu 23 - System Password** as shown below.

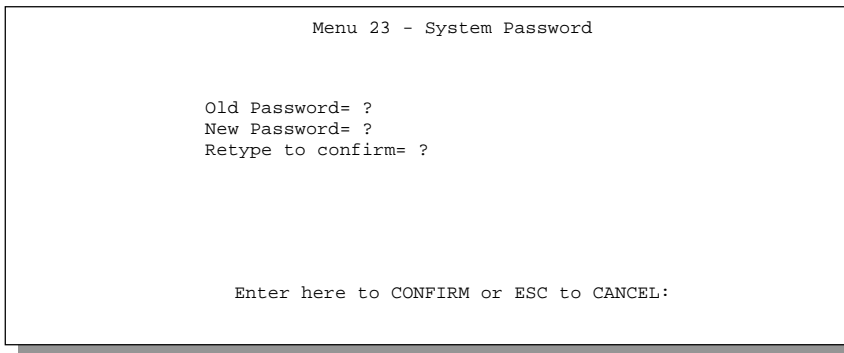

```

Menu 23 - System Password

Old Password= ?
New Password= ?
Retype to confirm= ?

Enter here to CONFIRM or ESC to CANCEL:

```

Figure 2-6 Menu 23 - System Security

Step 2. Enter your existing password and press [Enter].

Step 3. Enter your new system password and press [Enter].

Step 4. Re-type your new system password for confirmation and press [Enter].

Note that as you type a password, the screen displays a (X) for each character you type.

2.6.1 Resetting the Prestige

If you have forgotten your password or for some reason cannot access the SMT menu you will need to reinstall the configuration file. Uploading the configuration file replaces the current configuration file with the default configuration file, you will lose all configurations that you had before and the speed of the

console port will be reset to the default of 9600bps with 8 data bit, no parity and 1 stop bit (8n1). The password will be reset to the default of 1234, also.

Turn off the Prestige and begin a terminal emulation software session with the default console port settings. Turn on the Prestige again. When you see the message "Press Any key to enter Debug Mode within 3 seconds", press any key to enter debug mode. You should already have downloaded the correct file from your nearest ZyXEL FTP site. See *section 10-3* for more information on how to transfer the configuration file to your Prestige.

2.7 General Setup

Menu 1 - General Setup contains administrative and system-related information. The fields for General Setup are as shown next. **System Name** is for identification purposes. However, because some ISPs check this name you should enter your PC's "Computer Name" (Start -> Settings -> Control Panel -> Network. Click the Identification tab, note the entry for the Computer name" field). It is the domain name that will be propagated to the DHCP clients on the LAN. If you leave this blank, the domain name obtained by DHCP from the ISP is used. While you must enter the host name (**System Name**) on each individual machine, the domain name can be assigned from the Prestige via DHCP.

2.7.1 Dynamic DNS

Dynamic DNS allows you to update your current dynamic IP address with one or many dynamic DNS services so that anyone can contact you (in *NetMeeting*, *CU-SeeMe*, etc.) or access your FTP server or Web site on your own computer using a DNS-like address (e.g. *myhost.dhs.org*, where *myhost* is a name of your choice) which will never change instead of using your IP address that changes each time you reconnect. Your friends or relatives will always be able to call you even if they don't know your IP address.

First of all, you need to have registered a dynamic DNS account with www.dyndns.org. This is for people with a dynamic IP from their ISP or DHCP server that would still like to have a DNS name.

To use this service, you must register with the Dynamic DNS client. The Dynamic DNS Client service provider will give you a password or key. The Prestige at the time of writing supports www.ddns.org and www.dyndns.org clients. You can apply to either of these clients for Dynamic DNS service.

DYNDNS Wildcard

Enabling the wildcard feature for your host causes *.yourhost.dyndns.org to be aliased to the same IP address as yourhost.dyndns.org. This feature is useful if you want to be able to use for example www.yourhost.dyndns.org and still reach your hostname.

To enter Menu 1 and fill in the required information, follow these steps:

Step 1. Enter 1 in the Main Menu to open **Menu 1 – General Setup**.

Step 2. The **Menu 1 - General Setup** screen appears, as shown below. Fill in the required fields.

```

Menu 1 - General Setup

System Name= xxx
Domain Name=zyxel.com.tw
Edit Dynamic DNS= No

Press ENTER to Confirm or ESC to Cancel:

```

Figure 2-7 Menu 1 – General Setup**Table 2-5 General Setup Menu Field**

Field	Description	Example
System Name	Choose a descriptive name for identification purposes. It is recommended you enter your computer's "Computer name" in this field. This name can be up to 30 alphanumeric characters long. Spaces are not allowed, but dashes "-" and underscores "_" are accepted.	P310
Domain Name	Enter the domain name (if you know it) here. If you leave this field blank, the ISP may assign a domain name via DHCP. You can go to Menu 24.8 and type "sys domainname" to see the current domain name used by your gateway. If you want to clear this field just press the [SPACE BAR]. The domain name entered by you is given priority over the ISP assigned domain name.	zyxel.com.tw
Edit Dynamic DNS	Press the [SPACE BAR] to select Yes or No (default). Select Yes to configure Menu 1.1 – Configure Dynamic DNS discussed next.	

2.7.2 Configuring Dynamic DNS

To configure Dynamic DNS, go to **Menu 1 – General Setup** and press select **Yes** in the **Edit Dynamic DNS** field.

Pressing [ENTER] takes you to **Menu 1.1– Configure Dynamic DNS** as shown next.

```
Menu 1.1 - Configure Dynamic DNS

Service Provider = WWW.DynDNS.ORG
Active= Yes
Host= me.ddns.org
EMAIL= mail@mailserver
User= username
Password= *****
Enable Wildcard= No

Press ENTER to confirm or ESC to cancel:
```

Figure 2-8 Configure Dynamic DNS

Follow the instructions in the next table to configure Dynamic DNS parameters.

Table 2-6 Configure Dynamic DNS Menu Fields

Field	Description	Example
Service Provider	Enter the name of your Dynamic DNS client.	www.ddns.org
Active	Press [SPACE BAR] to toggle between Yes or No.	Yes
Host	Enter the domain name assigned to your Prestige by your Dynamic DNS provider.	me.ddns.org
EMAIL	Enter your e-mail address.	mail@mailserver
User	Enter your user name.	
Password	Enter the password assigned to you.	
Enable Wildcard	Your Prestige supports DYNDNS Wildcard. Press [SPACE BAR] to toggle between Yes or No This field is N/A when you choose DDNS client as your service provider.	Yes

The IP address will be updated when you reconfigure Menu 1 or perform DHCP client renewal.

Please note that:

- ◆ The Prestige supports basic DDNS, i.e., insecure login and password.
 - ◆ If you have a private WAN IP address, then you can not use this service.
-

2.8 WAN Setup

This section describes how to configure the WAN using **Menu 2 – WAN (10Mbps Ethernet) Setup**. From the Main Menu, enter 2 to open Menu 2.

You only need to configure this menu if your WAN connection is a cable modem.

```

Menu 2 - WAN Setup
MAC Address:
Assigned By=IP address attached on LAN
IP Address= 192.168.1.12

Press ENTER to Confirm or ESC to Cancel:
Press Space Bar to Toggle

```

Figure 2-9 Menu 2 – WAN Setup

The MAC address field allows users to configure the WAN port's MAC Address by either using the factory default or cloning the MAC address from a workstation on your LAN. Once it is successfully configured, the address will be copied to the rom file (ZyNOS configuration file). It will not change unless you change the setting in **Menu 2** or upload a different rom file.

The following table contains instructions on how to configure your WAN setup.

Table 2-7 WAN Setup Menu Fields

Field	Description	Examples
MAC Address		
Assigned By	Press the [SPACEBAR] to choose either of the two methods of assigning a MAC Address. Choose Factory Default to select the factory assigned default MAC Address. Choose IP Address attached on LAN to use the MAC Address of that workstation whose IP you give in the following field.	Factory Default
IP Address	This field is applicable only if you choose IP Address attached on LAN method. Enter the IP address of the workstation on the LAN whose MAC you are cloning.	

Note: Your Prestige WAN Port is always set at half-duplex mode as most cable modems only support half-duplex mode. If your cable modem supports full-duplex mode, then you will be able to manually set it at half-duplex mode.

If the Prestige was set at half-duplex and the cable modem was set at full-duplex then the WAN port would not function properly.

2.9 LAN Setup

This section describes how to configure the LAN using **Menu 3 – LAN Setup (10/100Mbps Ethernet)**. From the Main Menu, enter 3 to open Menu 3.

```
Menu 3 - LAN Setup

1. LAN Port Filter Setup
2. TCP/IP and DHCP Setup

Enter Menu Selection Number:
```

Figure 2-10 Menu 3 - LAN Setup

2.9.1 LAN Port Filter Setup

This menu allows you to specify the filter sets that you wish to apply to the LAN traffic. You seldom need to filter the LAN traffic, however, the filter sets may be useful to block certain packets, reduce traffic and prevent security breaches.

```
Menu 3.1 - LAN Port Filter Setup

Input Filter Sets:
  protocol filters= 2
  device filters=
Output Filter Sets:
  protocol filters=
  device filters=

Press ENTER to Confirm or ESC to Cancel:
```

Figure 2-11 Menu 3.1 – LAN Port Filter Setup

Menu 3.2 is discussed in the next part of the manual. Please read on.

Chapter 3: Internet Access

This chapter shows you how to configure the LAN as well as the WAN of your Prestige for Internet access.

3.1 TCP/IP and DHCP for LAN

The Prestige has built-in DHCP server capability that assigns IP addresses and DNS servers to systems that support DHCP client capability.

3.1.1 Factory LAN Defaults

The LAN parameters of the Prestige are preset in the factory with the following values:

1. IP address of 192.168.1.1 with subnet mask of 255.255.255.0 (24 bits)
2. DHCP server enabled with 32 client IP addresses starting from 192.168.1.33.

These parameters should work for the majority of installations. If the parameters are satisfactory, you can skip to *section 3.2* to enter the DNS server address(es) if your ISP gives you explicit DNS server address(es). If you wish to change the factory defaults or to learn more about TCP/IP, please read on.

3.1.2 IP Address and Subnet Mask

Similar to the houses on a street that share a common street name, the machines on a LAN share one common network number, also.

Where you obtain your network number depends on your particular situation. If the ISP or your network administrator assigns you a block of registered IP addresses, follow their instructions in selecting the IP addresses and the subnet mask.

If the ISP did not explicitly give you an IP network number, then most likely you have a single user account and the ISP will assign you a dynamic IP address when the connection is established. If this is the case, it is recommended that you select a network number from 192.168.0.0 to 192.168.255.0 (ignoring the trailing zero) and you must enable the Network Address Translation feature of the Prestige. The Internet Assigned Number Authority (IANA) reserved this block of addresses specifically for private use; please do *not* use any other number unless you are told otherwise. Let's say you select 192.168.1.0 as the network number; which covers 254 individual addresses, from 192.168.1.1 to 192.168.1.254 (zero and 255 are reserved). In other words, the first 3 numbers specify the network number while the last number identifies an individual workstation on that network.

Once you have decided on the network number, pick an IP address that is easy to remember, e.g., 192.168.1.1, for your Prestige.

192.168.1.1 is the default Ethernet IP for the Prestige. If you select this IP address, the Prestige will automatically enable various default settings such as, enable DHCP Server, set this IP as the default gateway etc.

The subnet mask specifies the network number portion of an IP address. Your Prestige will compute the subnet mask automatically based on the IP address that you entered. You don't need to change the subnet mask computed by the Prestige unless you are instructed to do otherwise.

3.1.3 Private IP Addresses

Every machine on the Internet must have a unique address. If your networks are isolated from the Internet, e.g., only between your two branch offices, you can assign any IP addresses to the hosts without problems. However, the Internet Assigned Numbers Authority (IANA) has reserved the following three blocks of IP addresses specifically for private networks:

10.0.0.0 - 10.255.255.255
172.16.0.0 - 172.31.255.255
192.168.0.0 - 192.168.255.255

For this reason, it is recommended that you choose your network number from the above list. You can obtain your IP address from the IANA, from an ISP, or assigned from a private network. If you belong to a small organization and your Internet access is through an ISP, the ISP can provide you with the Internet addresses for your local networks. On the other hand, if you are part of a much larger organization, you should consult your network administrator for the appropriate IP addresses.

Regardless of your particular situation, do not create an arbitrary IP address; always follow the guidelines above. For more information on address assignment, please refer to RFC 1597, *Address Allocation for Private Internets* and RFC 1466, *Guidelines for Management of IP Address Space*.

3.1.4 RIP Setup

RIP (Routing Information Protocol) allows a router to exchange routing information with other routers. The **RIP Direction** field controls the sending and receiving of RIP packets. When set to **Both** or **Out Only**, the Prestige will broadcast its routing table periodically. When set to **Both** or **In Only**, it will incorporate the RIP information that it receives; when set to **None**, it will not send any RIP packets and will ignore any RIP packets received.

The **Version** field controls the format and the broadcasting method of the RIP packets that the Prestige sends (it recognizes both formats when receiving). **RIP-1** is universally supported; but RIP-2 carries more information. RIP-1 is probably adequate for most networks, unless you have an unusual network topology. Both **RIP-2B** and **RIP-2M** sends the routing data in RIP-2 format; the difference being that **RIP-2B** uses subnet broadcasting while **RIP-2M** uses multicasting. Multicasting can reduce the load on non-router machines since they generally do not listen to the RIP multicast address and so will not receive the RIP packets. However, if one router uses multicasting, then all routers on your network must use multicasting,

also. By default, **RIP direction** is set to **Both** for the LAN and **None** for the WAN and the **Version** set to **RIP-1**.

3.1.5 DHCP Configuration

DHCP (Dynamic Host Configuration Protocol, RFC 2131 and RFC 2132) allows the individual clients (workstations) to obtain the TCP/IP configuration at start-up from a server. You can configure the Prestige as a DHCP **Server**, **Relay** or **None**. When configured as a **Server**, the Prestige provides the TCP/IP configuration for the clients. If set to **None**, DHCP service will be disabled and you must have another DHCP sever on your LAN, or else the workstation must be manually configured. The Prestige can now also act as a surrogate DHCP server (**Relay**) where it relays IP address assignment from the actual real DHCP server to the clients.

IP Pool Setup

The Prestige is pre-configured with a pool of 32 IP addresses starting from 192.168.1.33 to 192.168.1.64. This configuration leaves 31 IP addresses (excluding the Prestige itself) in the lower range for other server machines, e.g., server for mail, FTP, telnet, web, etc., that you may have.

DNS Server Address

DNS (Domain Name System) is for mapping a domain name to its corresponding IP address and vice versa, e.g., the IP address of *www.zyxel.com* is 204.217.0.2. The DNS server is extremely important because without it, you must know the IP address of a machine before you can access it.

There are two ways that an ISP disseminates the DNS server addresses. The first is for an ISP to tell a customer the DNS server addresses, usually in the form of an information sheet, when you sign up. If your ISP does give you the DNS server addresses, enter them in the **DNS Server** fields in **DHCP Setup**. The second is to leave this field blank, i.e., 0.0.0.0 – in this case the Prestige acts as a DNS proxy.

Example of network properties for LAN servers with fixed IP#:

Choose an IP:	192.168.1.2 - 192.168.1.32; 192.168.1.65 - 192.168.1.254.
Netmask:	255.255.255.0
Gateway (or default route):	192.168.1.1 (Prestige LAN IP)
DNS server:	192.168.1.1
Domain:	(optional)

3.1.6 IP Multicast

Traditionally, IP packets are transmitted in one of either two ways - Unicast (1 sender – 1 recipient) or Broadcast (1 sender – everybody on the network). Multicast is a third way to deliver IP packets to *a group* of hosts on the network - not everybody.

IGMP (Internet Group Multicast Protocol) is a session-layer protocol used to establish membership in a Multicast group - it is not used to carry user data. IGMP version 2 (RFC 2236) is an improvement over version 1 (RFC 1112) but IGMP version 1 is still in wide use. If you would like to read more detailed information about interoperability between IGMP version 2 and version 1, please see sections 4 and 5 of RFC 2236. The class D IP address is used to identify host groups and can be in the range 224.0.0.0 to 239.255.255.255. The address 224.0.0.0 is not assigned to any group and is used by IP multicast computers. The address 224.0.0.1 is used for query messages and is assigned to the permanent group of all IP hosts (including gateways). All hosts must join the 224.0.0.1 group in order to participate in IGMP. The address 224.0.0.2 is assigned to the multicast routers group.

The Prestige supports both IGMP version 1 (**IGMP-v1**) and IGMP version 2 (**IGMP-v2**). At start up, the Prestige queries all directly connected networks to gather group membership. After that, the Prestige periodically updates this information. IP Multicasting can be enabled/disabled on the Prestige LAN and/or WAN interfaces using menus 3.2 (LAN) and 11.3 (WAN). Select **None** to disable IP Multicasting on these interfaces.

3.1.7 IP Alias

IP Alias allows you to partition a physical network into different logical networks over the same Ethernet interface. The Prestige supports three logical LAN interfaces via its single physical Ethernet interface with the Prestige itself as the gateway for each LAN network.

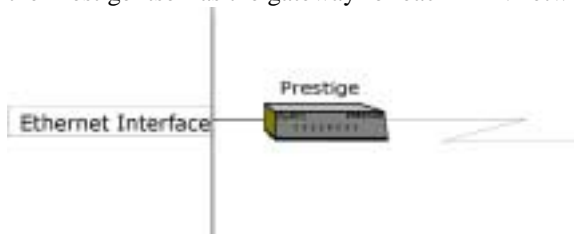

Figure 3-1 Physical Network

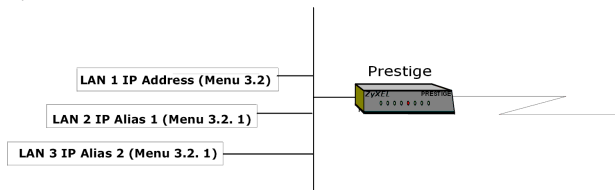

Figure 3-2 Partitioned Logical Networks

Use menu 3.2.1 to configure IP Alias on your Prestige.

3.2 TCP/IP and DHCP Ethernet Setup

From the Main Menu, enter 3 to open **Menu 3 - LAN Setup** (10/100 Mbps Ethernet) to configure TCP/IP (RFC 1155) and DHCP Ethernet setup.

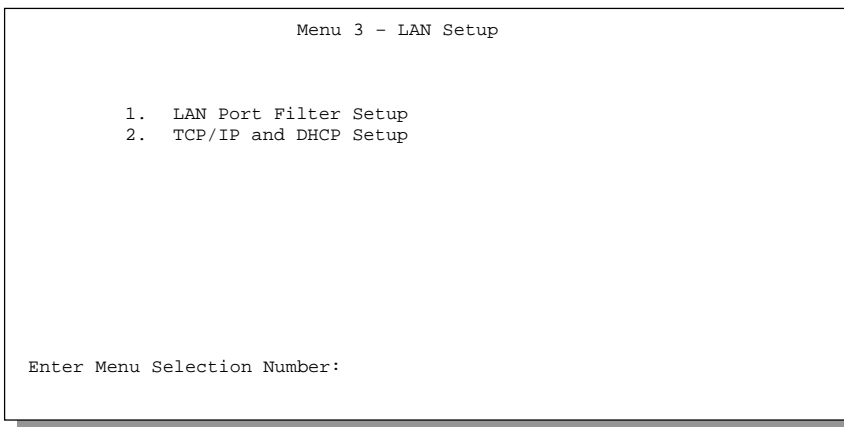

Figure 3-3 Menu 3 - LAN Setup (10/100 Mbps Ethernet)

To edit the TCP/IP and DHCP configuration, enter 2 to open **Menu 3.2 - TCP/IP and DHCP Ethernet Setup** as shown next.

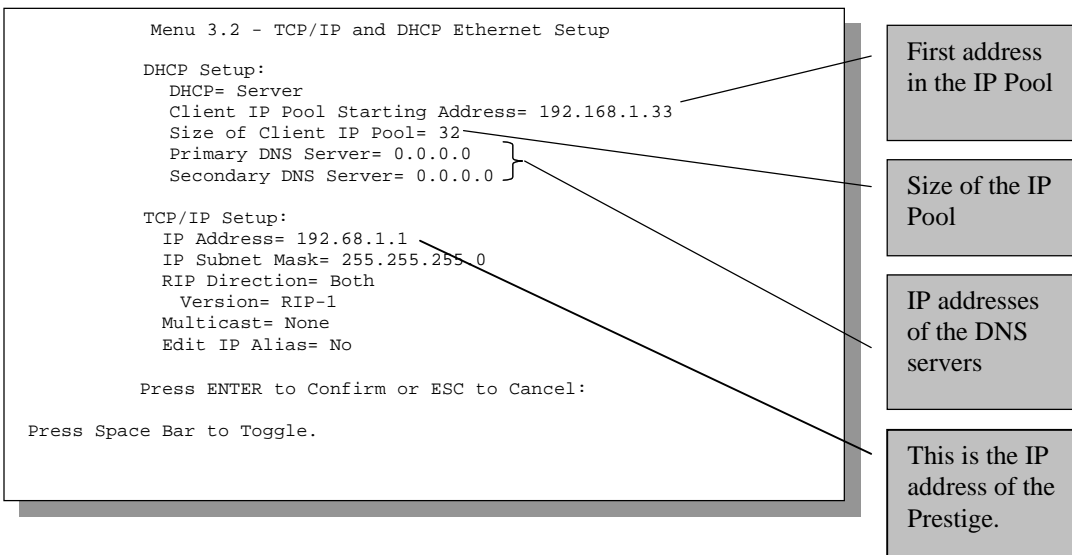

Figure 3-4 Menu 3.2 – TCP/IP and DHCP Ethernet Setup

Follow the instructions in the following table on how to configure the DHCP fields.

Table 3-1 LAN DHCP Setup Menu Fields

Field	Description	Example
DHCP=	This field enables/disables the DHCP server. If it is set to Server , your Prestige will act as a DHCP server. If set to None , DHCP service will be disabled and you must have another DHCP sever on your LAN, or else the workstation must be manually configured. When DHCP is set to Server , the following four items need to be set. The Prestige can now also act as a surrogate DHCP server (Relay) where it relays IP address assignment from the actual real DHCP server to the clients.	None Relay Server (default)
Client IP Pool Starting Address	This field specifies the first of the contiguous addresses in the IP address pool.	192.168.1.33
Size of Client IP Pool	This field specifies the size, or count, of the IP address pool.	32
Primary DNS Server Secondary DNS Server	Enter the IP addresses of the DNS servers. The DNS servers are passed to the DHCP clients along with the IP address and the subnet mask. Leave these entries at 0.0.0.0 if they are provided by a WAN DHCP server.	

Follow the instructions in the following table to configure TCP/IP parameters for the LAN port.

Table 3-2 LAN TCP/IP Setup Menu Fields

Field	Description	Example
TCP/IP Setup		
IP Address	Enter the IP address of your Prestige in dotted decimal notation	192.168.1.1 (default)
IP Subnet Mask	Your Prestige will automatically calculate the subnet mask based on the IP address that you assign. Unless you are implementing subnetting, use the subnet mask computed by the Prestige	255.255.255.0
RIP Direction	Press the [SPACE BAR] to select the RIP direction from Both/In Only/Out Only/None .	Both (default)
Version	Press the [SPACE BAR] to select the RIP version from RIP-1/RIP-2B/RIP-2M .	RIP-1 (default)
Multicast	IGMP (Internet Group Multicast Protocol) is a session-layer protocol used to establish membership in a Multicast group. The Prestige supports both IGMP version 1 (IGMP-v1) and IGMP-v2. Press the	None

Field	Description	Example
	space bar to enable IP Multicasting or select None (default) to disable it.	
Edit IP Alias	The Prestige supports three logical LAN interfaces via its single physical Ethernet interface with the Prestige itself as the gateway for each LAN network. Press the space bar to toggle No to Yes, then press [ENTER] to bring you to menu 3.2.1	Yes No (default)

When you have completed this menu, press [Enter] at the prompt [Press ENTER to Confirm...] to save your configuration, or press [Esc] at any time to cancel.

3.2.1 IP Alias Setup

You must use **Menu 3.2** to configure the first network and move the cursor to the **Edit IP Alias** field and press [SPACE BAR] to choose **Yes** and press [ENTER] to configure the second and third network. Pressing [Enter] opens **Menu 3.2.1 - IP Alias Setup**, as shown next.

```

Menu 3.2.1 - IP Alias Setup

IP Alias 1= No
IP Address= N/A
IP Subnet Mask= N/A
RIP Direction= N/A
Version= N/A
Incoming protocol filters= N/A
Outgoing protocol filters= N/A
IP Alias 2= No
IP Address= N/A
IP Subnet Mask= N/A
RIP Direction= N/A
Version= N/A
Incoming protocol filters= N/A
Outgoing protocol filters= N/A

Enter here to CONFIRM or ESC to CANCEL:

Press Space Bar to Toggle.
    
```

Figure 3-5 Menu 3.2.1 - IP Alias Setup

Follow the instructions in the following table to configure IP Alias parameters.

Table 3-3 IP Alias Setup Menu Fields

Field	Description	Example
IP Alias	Choose Yes to configure the LAN network for the Prestige.	Yes
IP Address	Enter the IP address of your Prestige in dotted decimal notation	192.168.2.1
IP Subnet Mask	Your Prestige will automatically calculate the subnet mask based on the IP address that you assign. Unless you are implementing	255.255.255.0

	subnetting, use the subnet mask computed by the Prestige	
RIP Direction	Press the space bar to select the RIP direction from None, Both/In Only/Out Only.	None
Version	Press the space bar to select the RIP version from RIP-1/RIP-2B/RIP-2M.	RIP-1
Incoming Protocol Filters	Enter the filter set(s) you wish to apply to the incoming traffic between this node and the Prestige.	
Outgoing Protocol Filters	Enter the filter set(s) you wish to apply to the outgoing traffic between this node and the Prestige.	
When you have completed this menu, press [Enter] at the prompt [Press ENTER to Confirm...] to save your configuration, or press [Esc] at any time to cancel.		

3.3 Internet Access Setup

You will see three different Menu 4 screens depending on whether you chose **Ethernet**, **PPTP** or **PPPoE Encapsulation**.

3.3.1 Ethernet Encapsulation

Step 1. You must choose the **Ethernet** option when the WAN port is used as a regular Ethernet. The PPPoE choice is for a dial-up connection using PPPoE. If you choose **Ethernet** in **Menu 4** you will see the next screen.

```

Menu 4 - Internet Access Setup

ISP's Name= ChangeMe
Encapsulation= Ethernet
Service Type= Standard
My Login= N/A
My Password= N/A
Login Server IP= N/A

IP Address Assignment= Dynamic
IP Address= N/A
IP Subnet Mask= N/A
Gateway IP Address= N/A
Single User Account= Yes

Press ENTER to Confirm or ESC to Cancel:
    
```

Figure 3-6 Internet Access Setup (Ethernet)

The following table describes this screen.

Table 3-4 Internet Access Setup Menu Fields

Field	Description
ISP's Name	Enter the name of your Internet Service Provider, e.g., myISP. This information is for identification purposes only.
Encapsulation	Press the [SPACE BAR] and the press [ENTER] to choose Ethernet. The encapsulation method influences your choices for IP Address.
Service Type	This is applicable only when you choose Ethernet as your encapsulation method. Press the [SPACE BAR] to select Standard, RR-Toshiba (RoadRunner Toshiba authentication method) or RR-Manager (RoadRunner Manager authentication method). Choose a RoadRunner flavor if your ISP is Time Warner's RoadRunner; otherwise choose Standard.
Note: xDSL users must choose the Standard option only. The Server IP, My Login IP and My Password fields are not applicable in this case.	
My Login Name	Enter the login name given to you by your ISP.
My Password	Enter the password associated with the login name above.
Login Server IP	The Prestige will find the RoadRunner Server IP if this field is left blank. If it does not, then you must enter the authentication server IP address.
IP Address Assignment	If your ISP did not assign you a fixed IP address, select Dynamic, otherwise select Static and enter the IP address & subnet mask in the following fields.
IP Address	Enter the (fixed) IP address assigned to you by your ISP (Static IP Address Assignment is selected in the previous field).
IP Subnet Mask	Enter the subnet mask associated with your static IP.
Gateway IP Address	Enter the gateway IP address associated with your static IP.
Single User Account	Please see the following chapter for a more detailed discussion on the Single User Account. The default is Yes.

3.3.2 PPTP Encapsulation

Point-to-Point Tunneling Protocol (PPTP) is a network protocol that enables secure transfer of data from a remote client to a private server, creating a Virtual Private Network (VPN) using TCP/IP-based networks. PPTP supports on-demand, multi-protocol, and virtual private networking over public networks, such as the Internet.

The P310 supports only one PPTP server connection at any given time.

3.3.3 Configure PPTP Client

To configure a PPTP client, you must configure **My Login** and **Password** fields for PPP connection and PPTP parameters for PPTP connection.

After configuring the **User Name** and **Password** for PPP connection, toggle the space bar in the **Encapsulation** field in **Menu 4 -Internet Access Setup** to choose **PPTP** as your encapsulation option. If you choose **PPTP** in **Menu 4** you will see the next screen.

```

Menu 4 - Internet Access Setup

ISP's Name= ChangeMe
Encapsulation= PPTP
Service Type= N/A
My Login= username
My Password= *****
Idle Timeout= 100

IP Address Assignment= Dynamic
IP Address= N/A
IP Subnet Mask= N/A
Gateway IP Address=N/A
Single User Account= Yes

Press ENTER to Confirm or ESC to Cancel:

```

Figure 3-7 Internet Access Setup (PPTP)

The following table contains instructions about the new fields when you choose **PPTP** in the **Encapsulation** field in **Menu 4**.

Table 3-5 New Fields in Menu 4 (PPTP) screen

Field	Description	Examples
Encapsulation	Press the [SPACE BAR] and then press [ENTER] to choose PPTP. The encapsulation method influences your choices for IP Address.	PPTP
Idle Timeout	This value specifies the time in seconds that elapses before the Prestige automatically disconnects from the PPTP server.	100 (default)

3.3.4 PPPoE Encapsulation

The Prestige supports PPPoE (Point-to-Point Protocol over Ethernet). You can use PPPoE encapsulation only when you're using the Prestige with an xDSL modem as the WAN device.

PPPoE is an IETF Draft standard specifying how a host personal computer (PC) interacts with a broadband modem (i.e. xDSL, cable, wireless, etc.) to achieve access to high-speed data networks. It preserves the existing Microsoft Dial-Up Networking experience and requires no new learning or procedures.

Operationally, PPPoE saves significant effort for both the end user and ISP/carrier, as it requires no configuration of the modem at the customer site.

PPPoE uses industry-standard, low-cost Ethernet NICs to connect your PCs to the broadband modem. In addition, PPPoE allows multiple PCs to share a single broadband connection, making it the best solution for small offices and homes that have more than one PC needing high-speed network access. For the service provider, one of the benefits of PPPoE is the ability to let end users access multiple network services, a function known as dynamic service selection. This enables the service provider to easily create and offer new IP services.

If you choose **PPPoE** in **Menu 4**, you will see the next screen. For extra information on PPPoE, please see the appendix.

```
Menu 4 - Internet Access Setup

ISP's Name= ChangeMe
Encapsulation= PPPoE
Service Type= N/A
My Login=
My Password= *****
Idle Timeout= 100

IP Address Assignment= Dynamic
IP Address= N/A
IP Subnet Mask= N/A
Gateway IP Address= N/A
Single User Account= Yes

Press ENTER to Confirm or ESC to Cancel:
```

Figure 3-8 Internet Access (PPPoE)

Table 3-6 New Fields in Menu 4 (PPPoE) screen

Field	Description	Examples
Encapsulation	Press the [SPACE BAR] and then press [ENTER] to choose PPPoE. The encapsulation method influences your choices for IP Address.	PPPoE
Idle Timeout	This value specifies the time in seconds that elapses before the Prestige automatically disconnects from the PPPoE server.	100 (default)

3.4 Internet Test Setup

After configuring the Menu 4 fields when you press [Enter] to confirm you will see the message, " Do you wish to perform the Internet Setup Test[y/n]:" if you have chosen PPTP or PPPoE as your encapsulation method. Say 'Y' to test your setup. An example of Internet Setup Test is shown next.

```
Start dialing for node <ChangeMe>...
### Hit any key to continue.###
$$$ DIALING dev=a ch=0.....
$$$ OUTGOING-CALL phone()
$$$ PPTP: Start tunnel setup, send SCCRQ
$$$ PPTP: OCRQ sent
$$$ CALL CONNECT speed<10000000> type<10> chan<0>
$$$ LCP opened
$$$ CHAP login to remote OK
$$$ IPCP negotiation started
$$$ CCP stopped
$$$ BACP stopped
$$$ IPCP neg' Primary DNS 202.xxx.xxx.x
$$$ IPCP opened
```

Figure 3-9 Internet Setup Test Example

3.5 Basic Setup Complete

Well Done! You have successfully connected, installed and set up your Prestige to operate on your network as well as access the Internet.

Part II:

Advanced Applications

Advanced Applications (Chapters 4-6) describe the advanced applications of your Prestige, such as Remote Node Setup, IP Static routes Setup and configuring SUA servers.

Chapter 4: SUA and Multiple SUA Servers

This chapter helps you in configuring SUA and setting up multiple inside servers in SUA case.

4.1 Single User Account (SUA)

If you wish to know more about SUA please read on. Or you can skip to the section *Single User Account Configuration* for configuring SUA and the section *Multiple Servers behind SUA* for information about setting up multiple servers when SUA is enabled.

4.1.1 Basics

Typically, if there are multiple users on the LAN wanting to concurrently access the Internet, you will have to lease a block of legal, or globally unique, IP addresses from the ISP.

Your Prestige accomplishes address sharing by translating the internal LAN IP addresses to a single address that is globally unique on the Internet. The SUA feature allows you to have the same benefits as having multiple legal addresses, but allows you to have one legal IP address and many local LAN IP addresses that can be used in other domains also, thus conserving the number of global IP addresses.

The Single User Account feature may also be used on connections to remote networks other than the ISP. For example, this feature can be used to simplify the allocation of IP addresses when connecting branch offices to the corporate network.

The IP address for the SUA can be either fixed or dynamically assigned. In addition, you can designate servers, e.g., a web server, on your local network in the client side and make them accessible to outside world.

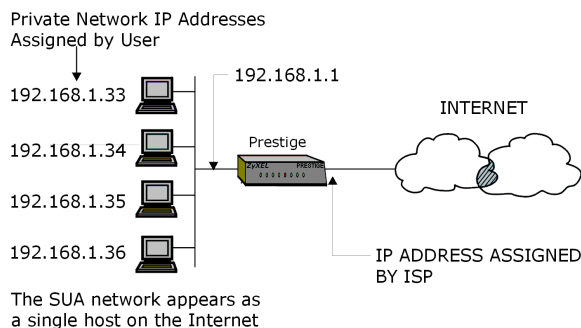

Figure 4-1 An Example of Single User Account Topology

SUA offers the additional benefit of firewall protection. All incoming inquiries will be filtered out by your Prestige and thus preventing intruders from probing your network.

For more information on IP address translation as a solution for IP address depletion problem, refer to RFC 1631, *The IP Network Address Translator (NAT)*.

In summary:

- SUA helps in more efficient IP address management.
- SUA can provide firewall protection. All incoming inquiries will be filtered out by your Prestige.
- UDP and TCP datagrams can be routed. In addition, partial ICMP, including echo (ping) and trace route, is supported.
- SUA is also a cost-effective solution for offices to access the Internet or other remote TCP/IP networks as they have to pay for single globally unique IP address only.

4.1.2 Single User Account Configuration

The steps for configuring your Prestige for Single User Account are identical to conventional Internet access (See configuration instructions in the previous chapter) with the exception that you need to fill in two extra fields in **Menu 4 - Internet Access Setup**, as shown in the following figure. SUA here is applied solely to the output interface and is valid *only* for LAN to WAN connections and *not* for connections between LANs.

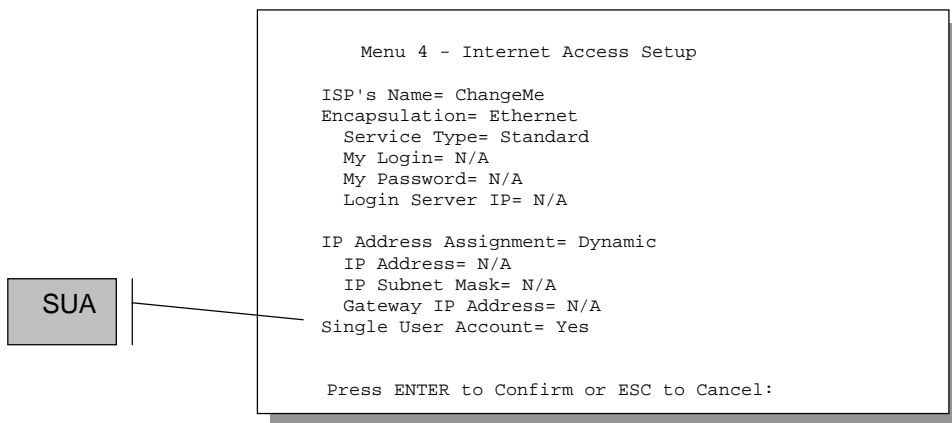

Figure 4-2 Menu 4 - Internet Access Setup for Single User Account

To enable the SUA feature in **Menu 4**, move the cursor to the **Single User Account** field and select **Yes** (or **No** to disable SUA).

Follow the instructions on how to configure the SUA fields in the following table.

Table 4-1 Single User Account Menu Fields

Field	Description
Single User Account	Select Yes to enable SUA.
Press [ENTER] at the message [Press ENTER to Confirm ...] to save your configuration, or press [ESC] at any time to cancel.	

When SUA is disabled, the Prestige will send the packets from workstations to the remote host with workstation's IP and port to the destination's IP and port. If the workstation uses private IP (Private Networks IPs: 10.0.0.0 ~ 10.255.255.255; 172.16.0.0. ~ 172.31.255.255; 192.168.0.0. ~ 192.168.255.255) in SUA mode, the packet will be routed by the Prestige but will be dropped somewhere and never returned. This is because only a legal IP is valid on the Internet. Hence, in non-SUA mode, the workstation must use non-private/legal IP.

4.2 Multiple Servers behind SUA

If you wish, you can make inside servers for different services, e.g., web or FTP, visible to the outside users, even though SUA makes your whole inside network appear as a single machine to the outside world. A service is identified by the port number, e.g., web service is on port 80 and FTP on port 21.

As an example, if you have a web server at 192.168.1.2 and an FTP server 192.168.1.3, then you need to specify for port 80 (web) the server at IP address 192.168.1.2 and for port 21 (FTP) another at IP address 192.168.1.3.

Please note that a server can support more than one service, e.g., a server can provide both FTP and DNS service, while another provides only web service. Also, since you need to specify the IP address of a server in the Prestige, a server must have a fixed IP address and not be a DHCP client whose IP address potentially changes each time it is powered on.

In addition to the servers for specific services, SUA supports a default server. A service request that does not have a server explicitly designated for it is forwarded to the default server. If the default server is not defined, the service request is simply discarded.

To make a server visible to the outside world, specify the port number of the service and the inside IP address of the server in **Menu 15, Multiple Server Configuration**.

For more information on configuring supporting applications behind SUA refer to the Zynos Support Note documentation in your Support CD.

4.2.1 Configuring a Server behind SUA

Follow the steps below to configure a server behind SUA:

- Step 1** Enter 15 in the main menu to go to **Menu 15 - Multiple Server Configuration**.
- Step 2** Enter the service port number in the **Port #** field and the inside IP address of the server in the **IP Address** field.
- Step 3** Press [Enter] at the "Press ENTER to confirm ..." prompt to save your configuration after you define all the servers or press ESC at any time to cancel.

```
Menu 15 - Multiple Server Configuration

Port #           IP Address
----           -
1.Default       0.0.0.0
2. 0            0.0.0.0
3. 0            0.0.0.0
4. 0            0.0.0.0
5. 0            0.0.0.0
6. 0            0.0.0.0
7. 0            0.0.0.0
8. 0            0.0.0.0
9. 1025         0.0.0.0
                RR Reserved

Press ENTER to Confirm or ESC to Cancel:
```

Figure 4-3 Multiple Server Configuration

The most often used port numbers are:

Table 4-2 Services vs. Port number

Services	Port Number
FTP (File Transfer Protocol)	21
Telnet	23
SMTP (Simple Mail Transfer Protocol)	25
DNS(Domain Name System)	53
HTTP (Hyper Text Transfer protocol or WWW, Web)	80
POP3 (Post Office Protocol, version 3)	110
PPTP (Point-to-Point Tunneling Protocol)	1723

Chapter 5

Remote Node Setup

This chapter shows you how to configure a remote node.

A remote node is required for placing calls to a remote gateway. A remote node represents both the remote gateway and the network behind it across a WAN connection. Note that when you use Menu 4 to set up Internet access, you are actually configuring a remote node. We will show you how to configure **Menu 11.1 Remote Node Profile**, **Menu 11.3 - Remote Node Network Layer Options** and **Menu 11.5 - Remote Node Filter**.

5.1 Remote Node Profile

From the Main Menu, select menu option 11 to open **Menu 11.1 - Remote Node Profile**. There are three variations of this menu depending on whether you choose **Ethernet Encapsulation**, **PPTP** or **PPPoE Encapsulation**.

5.1.1 Ethernet Encapsulation

You must choose the **Ethernet** option when the WAN port is used as a regular Ethernet. The first Menu 11.1 screen you see is for **Ethernet Encapsulation** shown next.

```
Menu 11.1 - Remote Node Profile

Rem Node Name= ChangeMe          Route= IP
Active= Yes

Encapsulation= Ethernet          Edit IP= No
Service Type= Standard          Session Options:
Service Name= N/A              Edit Filter Sets= No
Outgoing=
  My Login= N/A
  My Password= N/A
  Server IP= N/A

Press ENTER to Confirm or ESC to Cancel:
```

Figure 5-1 Menu 11.1 Remote Node Profile for Ethernet Encapsulation

Table 5-1 Fields in Menu 11.1 (Ethernet Encapsulation)

Field	Description	Examples
Rem Node Name	Enter a descriptive name for the remote node. This field can be up to eight characters.	LAoffice
Active	Press the [SPACE BAR] to toggle between Yes and No and activate (deactivate) the remote node.	Yes
Encapsulation	Ethernet is the default encapsulation. Press the [SPACE BAR] if you wish to change to PPPoE encapsulation.	Ethernet
Service Type	Press the [SPACE BAR] to select from Standard, RR-Toshiba (RoadRunner Toshiba authentication method) or RR-Manager (RoadRunner Manager authentication method). Choose one of the RoadRunner methods if your ISP is Time Warner's RoadRunner; otherwise choose Standard.	Standard
Service Name	This is valid only when you have chosen PPPoE encapsulation. If you are using PPPoE encapsulation, then type the name of your PPPoE service here.	poellc
Outgoing: My Login	This field is applicable for PPPoE encapsulation only. Enter the login name assigned by your ISP when the Prestige calls this remote node. Some ISPs append this field to the Service Name field above (e.g., <u>jim@poellc</u>) to access the PPPoE server.	jim
Outgoing: My Password	Enter the password assigned by your ISP when the Prestige calls this remote node. Valid for PPPoE encapsulation only.	*****
Authen= CHAP/PAP	This field sets the authentication protocol used for outgoing calls. Options for this field are: CHAP/PAP - Your Prestige will accept either CHAP or PAP when requested by this remote node. CHAP - accept CHAP only. PAP - accept PAP only.	CHAP/PAP
Server IP	This field is valid for RoadRunner service type only. The Prestige will find the RoadRunner Server IP automatically if this field is left blank. If it does not, then you must enter the authentication server IP address here.	
Route	This field refers to the protocol that will be routed by your Prestige – IP only for the P310.	IP
Edit IP	This field leads to a "hidden" menu. Press the [SPACE BAR] to select Yes and press [ENTER] to go to Menu 11.3 - Remote	Yes

Field	Description	Examples
	Node Network Layer Options.	
Session Options: Edit Filter sets	This field leads to another “hidden” menu Use the [SPACE BAR] to toggle this field to Yes and press [ENTER] to open Menu 11.5 to edit the filter sets. See the Remote Node Filter section for more details.	Yes

5.1.2 PPTP Encapsulation

If you change the **Encapsulation to PPTP** in **Menu 11.1**, then you will see the next screen. Please see the appendix for information.

```

Menu 11.1 - Remote Node Profile

Rem Node Name= ChangeMe           Route= IP
Active= Yes

Encapsulation= PPTP               Edit IP= No
Service Type= Standard            Telco Option:
Service Name=N/A                  Allocated Budget(min)= 0
Outgoing=                          Period(hr)= 0
  My Login=                        Schedules=
  My Password= *****            Nailed-up Connections=
  Authen= CHAP/PAP

PPTP :                             Session Options:
IP Addr=                           Edit Filter Sets= No
Server IP Addr=                     Idle Timeout(sec)= 100
Connection ID/Name=

Press ENTER to Confirm or ESC to Cancel:

Press Space Bar to Toggle.

```

Figure 5-2 Remote Node Profile for PPTP Encapsulation

The next table shows how to configure the new fields in the **Remote Node Profile** menu.

Table 5-2 Fields in Menu 11.1 (PPTP Encapsulation)

Field	Description	Examples
Encapsulation	Toggle the space bar to choose PPTP. You must also go to Menu 11.3 to check the IP Address setting once you have selected the encapsulation method.	PPTP

Field	Description	Examples
My IP Addr(ess)	Enter the IP address of the WAN Ethernet port.	10.0.0.140 (Default)
Server IP Addr(ess)	Enter the IP address of the ANT modem.	10.0.0.138 (Default)
Connection ID/Name	Enter the connection ID or connection name in the ANT. It must follow the “c:id” and “n:name” format. This field is optional and depends on the requirements of your xDSL Modem.	N:My ISP
Schedules	You can apply up to four schedule sets here. For more details please refer to the chapter <i>Call Schedule Setup</i> .	
Nailed-Up Connection	This field specifies if you want to make the connection to this remote node a nailed-up connection. For more details please refer to the section on <i>Nailed-Up Connection</i> .	

Nailed-Up Connection

A nailed-up connection is a dial-up line where the connection is always up regardless of traffic demand. The Prestige does two things when you specify a nailed-up connection. The first is that idle timeout is disabled. The second is that the Prestige will try to bring up the connection at power-on and whenever the connection is down. A nailed-up connection can be very expensive for obvious reasons.

Do not specify a nailed-up connection unless your telephone company offers flat-rate service or you need a constant connection and the cost is of no concern.

5.1.3 PPPoE Encapsulation

The Prestige supports PPPoE (Point-to-Point Protocol over Ethernet). You can use PPPoE encapsulation only when you're using the Prestige with an xDSL modem as the WAN device. If you change the **Encapsulation** to **PPPoE**, then you will see the next screen. Please see *section 3.3.2* for more information on PPPoE.

```

Menu 11.1 - Remote Node Profile

Rem Node Name= ChangeMe           Route= IP
Active= Yes

Encapsulation= PPPoE              Edit IP= No
Service Type= Standard            Telco Option:
Service Name=                     Allocated Budget(min)= 0
Outgoing=                          Period(hr)= 0
  My Login=                        Schedules
  My Password= *****            Nailed-up Connections=
  Authen= CHAP/PAP

Session Options:
Edit Filter Sets= No
Idle Timeout(sec)= 100

Press ENTER to Confirm or ESC to Cancel:

Press Space Bar to Toggle.

```

Figure 5-3 Menu 11.1 Remote Node Profile for PPPoE Encapsulation

The next table describes the fields NOT already described in *Table 5-1* already.

Table 5-3 Fields in Menu 11.1 (PPPoE Encapsulation Specific Only)

Field	Description	Examples
Telco Option: Allocated Budget	The field sets a ceiling for outgoing call time for this remote node. The default for this field is 0 meaning no budget control. See <i>section 11.2.1</i> for more information.	10
Period(hr)	This field is the time period that the budget should be reset. For example, if we are allowed to call this remote node for a maximum of 10 minutes every hour, then the Allocated Budget is (10 minutes) and the Period(hr) is 1 (hour).	1
Idle Timeout	This value specifies the idle time (i.e., the length of time there is no traffic from the Prestige to the remote node) in seconds that can elapse before the Prestige automatically disconnects the dial-up connection. <i><u>This option only applies when the Prestige initiates the call.</u></i>	100 seconds (default)
Schedules	You can apply up to four schedule sets here. For more details please refer to the chapter <i>Call Schedule Setup</i> .	
Nailed-Up Connection	This field specifies if you want to make the connection to this remote node a nailed-up connection. For more details please refer to the section on <i>Nailed-Up Connection</i> .	

5.2 Editing TCP/IP Options (with Ethernet Encapsulation)

Move the cursor to the **Edit IP** field in **Menu 11.1**, then press the [SPACE BAR] to toggle and set the value to **Yes**. Press [Enter] to open **Menu 11.3 - Network Layer Options**.

```

Menu 11.3 - Remote Node Network Layer Options

IP Address Assignment= Dynamic
IP Address= N/A
IP Subnet Mask= N/A
Gateway IP Addr= N/A

Single User Account= Yes
Metric= N/A
Private= N/A
RIP Direction= None
  Version= N/A
Multicast= None

Enter here to CONFIRM or ESC to CANCEL:
Press Space Bar to Toggle.
    
```

Figure 5-4 Remote Node Network Layer Options

The next table gives you instructions about configuring remote node network layer options.

Table 5-4 Remote Node Network Layer Options Menu Fields

Field	Description	Example
IP Address Assignment	If your ISP did not assign you an explicit IP address, select Dynamic; otherwise select Static and enter the IP address & subnet mask in the following fields.	Dynamic
IP Address	If you have a Static IP Assignment, enter the IP address assigned to you by your ISP.	
IP Subnet Mask	If you have a Static IP Assignment, enter the subnet mask assigned to you.	
Gateway IP Addr	If you have a Static IP Assignment, enter the gateway IP address assigned to you.	
Single User Account	Use the [SPACE BAR] to choose Yes or No.	Yes
Metric	This field is valid only for PPTP/ PPPoE encapsulation. The metric represents the “cost” of transmission for routing purposes. IP routing uses hop count as the measurement of cost, with a minimum of 1 for directly connected networks. Enter a number that approximates the cost for this link. The number need not be precise, but it must be	3

Field	Description	Example
	between 1 and 15. In practice, 2 or 3 is usually a good number.	
Private	This field is valid only for PPTP/PPPoE encapsulation. This parameter determines if the Prestige will include the route to this remote node in its RIP broadcasts. If set to Yes, this route is kept private and not included in RIP broadcast. If No, the route to this remote node will be propagated to other hosts through RIP broadcasts.	Yes
RIP	Press the [SPACE BAR] to select the WAN RIP direction from Both/None/In Only/Out Only.	None (default)
Version	Press the [SPACE BAR] to select the RIP version from RIP-1/RIP-2B/RIP-2M and None.	RIP-1
Multicast	Turn on/off IGMP support and select the version from IGMP-v2/IGMP-v1/None.	None
Once you have completed filling in the Network Layer Options Menu, press [Enter] to return to Menu 11. Press [Enter] at the message [Press ENTER to Confirm...] to save your configuration, or press [Esc] at any time to cancel.		

5.2.1 Editing TCP/IP Options (with PPTP Encapsulation)

Make sure that **Encapsulation** is set to **PPTP** in Menu 11.1. Then move the cursor to the **Edit IP** field in **Menu 11.1**, press the [SPACE BAR] to toggle **No** to **Yes**. Press [Enter] to open **Menu 11.3 - Network Layer Options**.

```

Menu 11.3 - Remote Node Network Layer Options

IP Address Assignment= Dynamic
Rem IP Address= N/A
Rem Subnet Mask= N/A
My WAN Addr= 0.0.0.0

Single User Account= Yes
Metric= 1
Private= No
RIP Direction= None
Version= N/A
Multicast= None

Enter here to CONFIRM or ESC to CANCEL:
Press Space Bar to Toggle.

```

Figure 5-5 Remote Node Network Layer Options

The next table gives you instructions about configuring remote node network layer options.

Table 5-5 Remote Node Network Layer Options Menu Fields

Field	Description	Example
IP Address Assignment	If your ISP did not assign you an explicit IP address, select Dynamic; otherwise select Static and enter the IP address & subnet mask in the following fields.	Dynamic
Rem IP Address	If you have a Static IP Assignment, enter the IP address assigned to the remote node.	
Rem IP Subnet Mask	If you have a Static IP Assignment, enter the subnet mask assigned to the remote node.	
My WAN Addr	Some implementations, especially the UNIX derivatives, require the WAN link to have a separate IP network number from the LAN and each end must have a unique address within the WAN network number. If this is the case, enter the IP address assigned to the WAN port of your Prestige. Note that this is the address assigned to your local Prestige, not the remote router.	
Single User Account	Use the [SPACE BAR] to choose Yes or No.	Yes
Metric	The metric represents the “cost” of transmission for routing purposes. IP routing uses hop count as the measurement of cost, with a minimum of 1 for directly connected networks. Enter a number that approximates the cost for this link. The number need not be precise, but it must be between 1 and 15. In practice, 2 or 3 is usually a good number.	1 to 15
Private	This parameter determines if the Prestige will include the route to this remote node in its RIP broadcasts. If set to Yes, this route is kept private and not included in RIP broadcast. If No, the route to this remote node will be propagated to other hosts through RIP broadcasts.	Yes/No
RIP	Press the [SPACE BAR] to select the RIP direction from Both/ None/In Only/Out Only and None.	None (default)
Version	Press the [SPACE BAR] to select the RIP version from RIP-1/RIP-2B/RIP-2M.	RIP-1
Multicast	Turn on/off IGMP support and select the version from IGMP-v2/IGMP-v1/None.	None
Once you have completed filling in the Network Layer Options Menu, press [Enter] to return to Menu 11. Press [Enter] at the message [Press ENTER to Confirm...] to save your configuration, or press [Esc] at any time to cancel.		

5.2.2 Editing TCP/IP Options (with PPPoE Encapsulation)

Make sure that **Encapsulation** is set to **PPPoE** in Menu 11.1. Then move the cursor to the **Edit IP** field in **Menu 11.1**, press the [SPACE BAR] to toggle **No** to **Yes**. Press [Enter] to open **Menu 11.3 - Network Layer Options**.

```

Menu 11.3 - Remote Node Network Layer Options

IP Address Assignment= Dynamic
Rem IP Address= N/A
Rem Subnet Mask= N/A
My WAN Addr= 0.0.0.0

Single User Account= Yes
Metric= 1
Private= No
RIP Direction= None
Version= N/A
Multicast= None

Enter here to CONFIRM or ESC to CANCEL:
Press Space Bar to Toggle.

```

Figure 5-6 Remote Node Network Layer Options

The next table gives you instructions about configuring remote node network layer options.

Table 5-6 Remote Node Network Layer Options Menu Fields

Field	Description	Example
IP Address Assignment	If your ISP did not assign you an explicit IP address, select Dynamic; otherwise select Static and enter the IP address & subnet mask in the following fields.	Dynamic
Rem IP Address	If you have a Static IP Assignment, enter the IP address assigned to the remote node.	
Rem IP Subnet Mask	If you have a Static IP Assignment, enter the subnet mask assigned to the remote node.	
My WAN Addr	Some implementations, especially the UNIX derivatives, require the WAN link to have a separate IP network number from the LAN and each end must have a unique address within the WAN network number. If this is the case, enter the IP address assigned to the WAN port of your Prestige. Note that this is the address assigned to your local Prestige, not the remote router.	
Single User Account	Use the [SPACE BAR] to choose Yes or No.	Yes

Field	Description	Example
Metric	The metric represents the “cost” of transmission for routing purposes. IP routing uses hop count as the measurement of cost, with a minimum of 1 for directly connected networks. Enter a number that approximates the cost for this link. The number need not be precise, but it must be between 1 and 15. In practice, 2 or 3 is usually a good number.	1 to 15
Private	This parameter determines if the Prestige will include the route to this remote node in its RIP broadcasts. If set to Yes, this route is kept private and not included in RIP broadcast. If No, the route to this remote node will be propagated to other hosts through RIP broadcasts.	Yes/No
RIP	Press the [SPACE BAR] to select the WAN RIP direction from Both/None/In Only/Out Only and None.	None (default)
Version	Press the [SPACE BAR] to select the RIP version from RIP-1/RIP-2B/RIP-2M.	RIP-1
Multicast	Turn on/off IGMP support and select the version from IGMP-v2/IGMP-v1/None.	None
Once you have completed filling in the Network Layer Options Menu, press [Enter] to return to Menu 11. Press [Enter] at the message [Press ENTER to Confirm...] to save your configuration, or press [Esc] at any time to cancel.		

5.3 Remote Node Filter

Move the cursor to the field **Edit Filter Sets** in **Menu 11.1**, then press the [SPACE BAR] to toggle and set the value to **YES**. Press [ENTER] to open **Menu 11.5 – Remote Node Filter**.

Use **Menu 11.5** to specify the filter set(s) to apply to the incoming and outgoing traffic between this remote node and the Prestige and to prevent certain packets from triggering calls. You can specify up to 4 filter sets separated by a comma, e.g., 1, 5, 9, 12, in each **filter** field.

Note that spaces are accepted in this field. For more information on defining the filters, please *refer to Chapter 7*. Note that for PPTP and PPPoE encapsulation, you can also specify remote node call filter sets.

```
Menu 11.5 - Remote Node Filter

Input Filter Sets:
  protocol filters= 3
  device filters=
Output Filter Sets:
  protocol filters= 1
  device filters=

Enter here to CONFIRM or ESC to CANCEL:
```

Figure 5-7 Remote Node Filter (Ethernet Encapsulation)

```
Menu 11.5 - Remote Node Filter

Input Filter Sets:
  protocol filters= 3
  device filters=
Output Filter Sets:
  protocol filters= 1
  device filters=
Call Filter Sets:
  protocol filters= 1
  device filters=

Enter here to CONFIRM or ESC to CANCEL:
```

Figure 5-8 Remote Node Filter (PPTP/PPPoE Encapsulation)

Chapter 6: IP Static Route Setup

This chapter shows you how to configure static routes with your Prestige.

Static routes tell the Prestige routing information that it cannot learn automatically through other means. This can arise in cases where RIP is disabled on the LAN.

Each remote node specifies only the network to which the gateway is directly connected, and the Prestige has no knowledge of the networks beyond. For instance, the Prestige knows about network N2 in the following diagram through remote node Router 1. However, the Prestige is unable to route a packet to network N3 because it doesn't know that there is a route through the same remote node Router 1 (via gateway Router 2). The static routes are for you to tell the Prestige about the networks beyond the remote nodes.

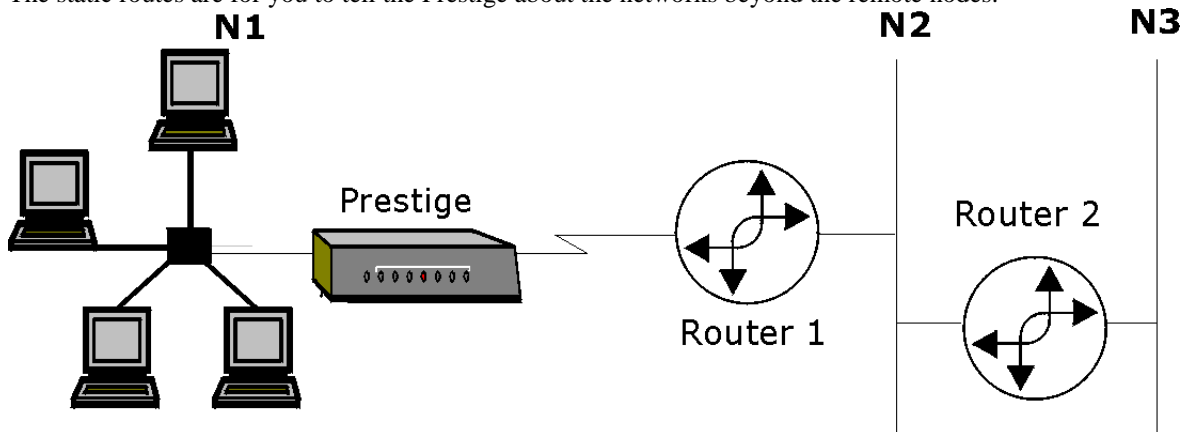

Figure 6-1 Example of Static Routing Topology

6.1 IP Static Route Setup

You configure IP static routes in **Menu 12. 1**, by selecting one of the IP static routes as shown below. Enter 12 from the Main Menu.

```
Menu 12 - IP Static Route Setup

1. _____
2. _____
3. _____
4. _____
5. _____
6. _____
7. _____
8. _____

Enter selection number:
```

Figure 6-2 Menu 12 - IP Static Route Setup

Now, enter the index number of one of the static routes you want to configure.

```
Menu 12.1 - Edit IP Static Route

Route #: 1
Route Name= ?
Active= No
Destination IP Address= ?
IP Subnet Mask= ?
Gateway IP Address= ?
Metric= 2
Private= No

Press ENTER to CONFIRM or ESC to CANCEL:
```

Figure 6-3 Menu 12. 1 - Edit IP Static Route

The next table describes the IP Static Route Menu fields.

Table 6-1 IP Static Route Menu Fields

Field	Description
Route #	This is the index number of the static route that you chose in Menu 12.
Route Name	Enter a descriptive name for this route. This is for identification purposes only.
Active	This field allows you to activate/deactivate this static route.
Destination IP Address	This parameter specifies the IP network address of the final destination. Routing is always based on network number. If you need to specify a route to a single host, use a subnet mask of 255.255.255.255 in the subnet mask field to force the network number to be identical to the host ID.
IP Subnet Mask	Enter the IP subnet mask for this destination.
Gateway IP Address	Enter the IP address of the gateway. The gateway is an immediate neighbor of your Prestige that will forward the packet to the destination. On the LAN, the gateway must be a router on the same segment as your Prestige; over the WAN, the gateway must be the IP address of one of the Remote Nodes.
Metric	Metric represents the “cost” of transmission for routing purposes. IP routing uses hop count as the measurement of cost, with a minimum of 1 for directly connected networks. Enter a number that approximates the cost for this link. The number need not be precise, but it must be between 1 and 15. In practice, 2 or 3 is usually a good number.
Private	This parameter determines if the Prestige will include the route to this remote node in its RIP broadcasts. If set to Yes, this route is kept private and not included in RIP broadcast. If No, the route to this remote node will be propagated to other hosts through RIP broadcasts.
Once you have completed filling in this menu, press [Enter] at the message [Press ENTER to Confirm...] to save your configuration, or press [Esc] to cancel.	

Part III:

Advanced Management

Chapters 7 - 11 provide information on Prestige filtering, System Information and Diagnosis, SNMP Configuration, Transferring Files and Telnet.

Chapter 7: Filter Configuration

This chapter shows you how to create and apply filter(s).

7.1 About Filtering

Your Prestige uses filters to decide whether to allow passage of a data packet and/or to make a call. There are two types of filter applications: data filtering and call filtering. Filters are subdivided into device and protocol filters, which are discussed later.

Data filtering screens the data to determine if the packet should be allowed to pass. Data filters are divided into incoming and outgoing filters, depending on the direction of the packet relative to a port. Data filtering can be applied on either the WAN side or the Ethernet side. Call filtering is used to determine if a packet should be allowed to trigger a call. Remote node call filtering is only applicable when using **PPTP or PPPoE** encapsulation (*see* Figure 5-8). Outgoing packets must undergo data filtering before they encounter call filtering as shown in the following figure.

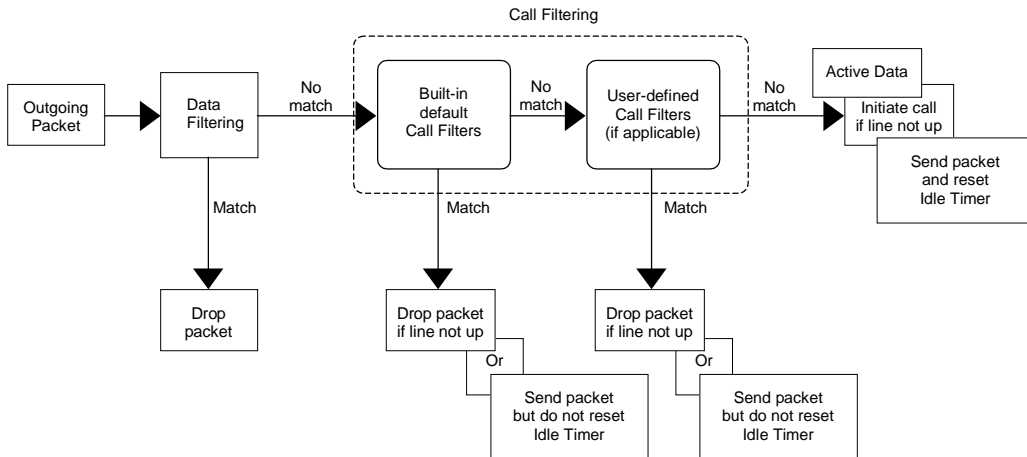

Figure 7-1 Outgoing Packet Filtering Process

For incoming packets, your Prestige applies data filters only. Packets are processed depending upon whether a match is found. The following sections describe how to configure filter sets

The following sections describe how to configure filter sets.

7.1.1 The Filter Structure of the Prestige

A filter set consists of one or more filter rules. Usually, you would group related rules, e.g., all the rules for NetBIOS, into a single set and give it a descriptive name. The Prestige allows you to configure up to twelve filter sets with six rules in each set, for a total of 72 filter rules in the system. You cannot mix device filter rules and protocol filter rules within the same set. You can apply up to four filter sets to a particular port to block multiple types of packets. With each filter set having up to six rules, you can have a maximum of 24 rules active for a single port.

Three sets of factory default filter rules have been configured in Menu 21 to prevent NetBIOS traffic from triggering calls and to prevent incoming telnetting and FTP connections from the WAN side. A summary of their filter rules is shown in the figures that follow.

The following diagram illustrates the logic flow when executing a filter rule.

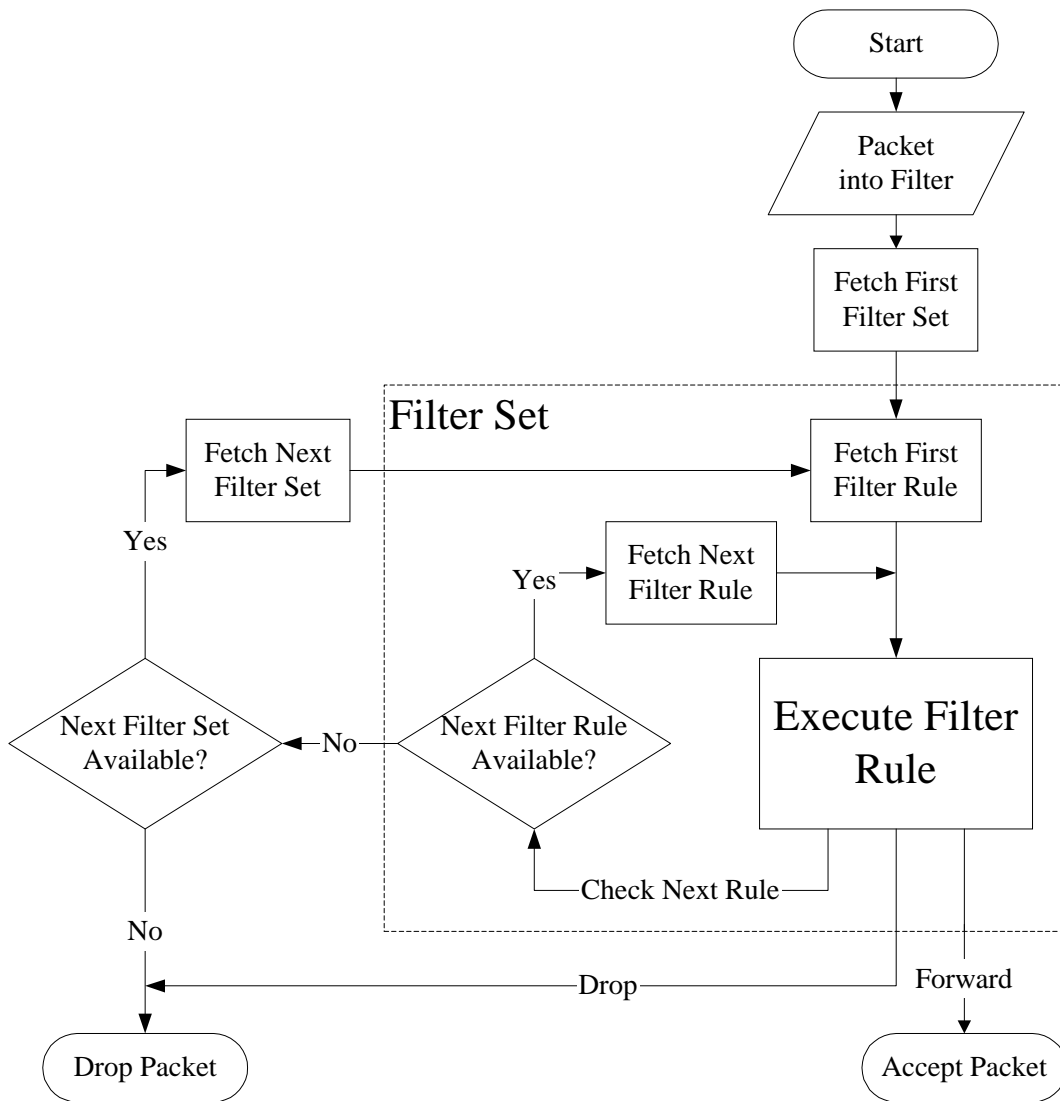

Figure 7-2 Filter Rule Process

You can apply up to four filter sets to a particular port to block multiple types of packets. With each filter set having up to six rules, you can have a maximum of 24 rules active for a single port.

7.2 Configuring a Filter Set

To configure a filter set, follow the procedure below. Select option **21. Filter Set Configuration** from the Main Menu to open **Menu 21**.

Step 1. Enter **1** to bring up the following menu.

```
Menu 21.1 - Filter Set Configuration

Filter          Filter
Set #          Set #
-----          -----
1             NetBIOS_WAN          7             _____
2             NetBIOS_LAN          8             _____
3             TEL_FTP_WEB_WAN    9             _____
4             _____        10            _____
5             _____        11            _____
6             _____        12            _____

Enter Filter Set Number to Configure= 0

Edit Comments=

Press ENTER to CONFIRM or ESC to CANCEL:
```

Figure 7-3 **Menu 21 - Filter Set Configuration**

Step 2. Select the filter set you wish to configure (no. 1-12) and press [Enter].

Step 3. Enter a descriptive name or comment in the **Edit Comments** field and press [Enter].

Step 4. Press [Enter] at the message: [Press ENTER to confirm] to open **Menu 21.1.1 - Filter Rules Summary**.

```

Menu 21.1 - Filter Rules Summary

# A Type                Filter Rules                M m n
-----
1 Y IP  Pr=6, SA=0.0.0.0, DA=0.0.0.0, DP=137      N D N
2 Y IP  Pr=6, SA=0.0.0.0, DA=0.0.0.0, DP=138      N D N
3 Y IP  Pr=6, SA=0.0.0.0, DA=0.0.0.0, DP=139      N D N
4 Y IP  Pr=17, SA=0.0.0.0, DA=0.0.0.0, DP=137     N D N
5 Y IP  Pr=17, SA=0.0.0.0, DA=0.0.0.0, DP=138     N D N
6 Y IP  Pr=17, SA=0.0.0.0, DA=0.0.0.0, DP=139     N D F

Enter Filter Rule Number (1-6) to Configure:

Press ENTER to Confirm or ESC to Cancel:

```

Figure 7-4 NetBIOS_WAN Filter Rules Summary

```

Menu 21.2 - Filter Rules Summary

# A Type                Filter Rules                M m n
-----
1 Y IP  Pr=17, SA=0.0.0.0, SP=137, DA=0.0.0.0, DP=53  N D F
2 Y
3 Y
4 Y
5 Y
6 Y

Enter Filter Rule Number (1-6) to Configure:

```

Figure 7-5 NetBIOS_LAN Filter Rules Summary

```

Menu 21.3 - Filter Rules Summary

# A Type                Filter Rules                M m n
-----
1 Y IP  Pr=6, SA=0.0.0.0, DA=0.0.0.0, DP=23          N D N
2 Y IP  Pr=6, SA=0.0.0.0, DA=0.0.0.0, DP=21          N D N
3 Y IP  Pr=6, SA=0.0.0.0, DA=0.0.0.0, DP=80          N D F
4 N
5 N
6 N

Enter Filter Rule Number (1-6) to Configure:

```

Figure 7-6 TEL_FTP_WEB_WAN Filter Rules Summary

7.2.1 Filter Rules Summary Menu

This screen shows the summary of the existing rules in the filter set. The following tables contain a brief description of the abbreviations used in the previous menus.

Table 7-1 Abbreviations Used in the Filter Rules Summary Menu

Abbreviations	Description	Display
#	Refers to the filter rule number (1-6).	
A	Shows whether the rule is active or not.	[Y] means the filter rule is active. [N] means the filter rule is inactive.
Type	Refers to the type of filter rule. This shows GEN for generic, IP for TCP/IP	[GEN] for Generic [IP] for TCP/IP
Filter Rules	The filter rule parameters will be displayed here (see below).	
M	Refers to More. [Y] means an action can not yet be taken as there are more rules to check, which are concatenated with the present rule to form a rule chain. When the rule chain is complete an action can be taken. [N] means you can now specify an action to be taken i.e., forward the packet, drop the packet or check the next rule. For the latter, the next rule is independent of the rule just checked. If More is Yes, then Action Matched and Action Not Matched will be N/A	[Y] means there are more rules to check. [N] means there are no more rules to check.
m	Refers to Action Matched. [F] means to forward the packet immediately and skip checking the remaining rules.	[F] means to forward the packet. [D] means to drop the packet. [N] means check the next rule.
n	Refers to Action Not Matched. [F] means to forward the packet immediately and skip checking the remaining rules.	[F] means to forward the packet. [D] means to drop the packet. [N] means check the next rule.

The protocol dependent filter rules abbreviation are listed as follows:

- If the filter type is IP, the following abbreviations listed in the following table will be used.

Table 7-2 Abbreviations Used If Filter Type Is IP

Abbreviation	Description
Pr	Protocol
SA	Source Address
SP	Source Port number
DA	Destination Address
DP	Destination Port number

- If the filter type is GEN (generic), the following abbreviations listed in the following table will be used.

Table 7-3 Abbreviations Used If Filter Type Is GEN

Abbreviation	Description
Off	Offset
Len	Length

Refer to the next section for information on configuring the filter rules.

7.2.2 Configuring a Filter Rule

To configure a filter rule, type its number in **Menu 21.1 - Filter Rules Summary** and press [Enter] to open **Menu 21.1.1** for the rule.

To speed up filtering, all rules in a filter set must be of the same class, i.e., protocol filters or generic filters. The class of a filter set is determined by the first rule that you create. When applying the filter sets to a port, separate menu fields are provided for protocol and device filter sets. If you include a protocol filter set in a device filter field or vice versa, the Prestige will warn you and will not allow you to save.

7.2.3 TCP/IP Filter Rule

This section shows you how to configure a TCP/IP filter rule. TCP/IP rules allow you to base the rule on the fields in the IP and the upper layer protocol, e.g., UDP and TCP, headers.

To configure a TCP/IP rules, select TCP/IP Filter Rule from the Filter Type field and press Enter to open **Menu 21.1.1 - TCP/IP Filter Rule**, as shown below.

```

Menu 21.1.1 - TCP/IP Filter Rule

Filter #: 1,1
Filter Type= TCP/IP Filter Rule
Active= Yes
IP Protocol= 6      IP Source Route= No
Destination: IP Addr= 0.0.0.0
               IP Mask= 0.0.0.0
               Port # = 137
               Port # Comp= Equal
Source: IP Addr= 0.0.0.0
          IP Mask= 0.0.0.0
          Port # =
          Port # Comp= None

TCP Estab= No
More= No      Log= None
Action Matched= Drop
Action Not Matched= Check Next Rule

Press ENTER to Confirm or ESC to Cancel:
Press Space Bar to Toggle.
    
```

Figure 7-7 Menu 21.1.1 - TCP/IP Filter Rule

The following table describes how to configure your TCP/IP filter rule.

Table 7-4 TCP/IP Filter Rule Menu Fields

Field	Description	Option
Active	This field activates/deactivates the filter rule.	Yes/No
IP Protocol	Protocol refers to the upper layer protocol, e.g., TCP is 6, UDP is 17 and ICMP is 1. This value must be between 0 and 255	0-255
IP Source Route	If Yes, the rule applies to packet with IP source route option; else the packet must not have source route option. The majority of IP packets do not have source route.	Yes/No
Destination: IP Address	Enter the destination IP Address of the packet you wish to filter. This field is a don't-care if it is 0.0.0.0.	IP address
Destination: IP Mask	Enter the IP mask that will be used to mask the bits of the IP address given in the Destination: IP Addr.	IP mask
Destination: Port #	Enter the destination port of the packets that you wish to filter. The range of this field is 0 to 65535. This field is a don't-care if it is 0.	0-65535
Destination: Port #	Select the comparison to apply to the destination port in	None/Less/Greater/E

Field	Description	Option
Comp	the packet against the value given in Destination: Port #.	qual/Not Equal]
Source: IP Address	Enter the source IP Address of the packet you wish to filter. This field is a don't-care if it is 0.0.0.0.	IP Address
Source: IP Mask	Enter the IP mask that will be used to mask the bits of the IP address given in the Source: IP Addr.	IP Mask
Source: Port #	Enter the source port of the packets that you wish to filter. The range of this field is 0 to 65535. This field is a don't-care if it is 0.	0-65535
Source: Port # Comp	Select the comparison to apply to the source port in the packet against the value given in Source: Port #.	None/Less/Greater/E qual/Not Equal
TCP Estab	This field is applicable only when IP Protocol field is 6, TCP. If yes, the rule matches only established TCP connections; else the rule matches all TCP packets.	Yes/No
More	If yes, a matching packet is passed to the next filter rule before an action is taken; else the packet is disposed of according to the action fields. If More is Yes, then Action Matched and Action Not Matched will be No.	Yes / No
Log	Select the logging option from the following: None – No packets will be logged. Action Matched - Only packets that match the rule parameters will be logged. Action Not Matched - Only packets that do not match the rule parameters will be logged. Both – All packets will be logged.	None Action Matched Action Not Matched Both
Action Matched	Select the action for a matching packet.	Check Next Rule Forward Drop
Action Not Matched	Select the action for a packet not matching the rule.	Check Next Rule Forward Drop

Field	Description	Option
	Once you have completed filling in Menu 21.1.1.1 - TCP/IP Filter Rule, press [Enter] at the message [Press Enter to Confirm] to save your configuration, or press [Esc] to cancel. This data will now be displayed on Menu 21.1.1 - Filter Rules Summary.	

The following diagram illustrates the logic flow of an IP filter.

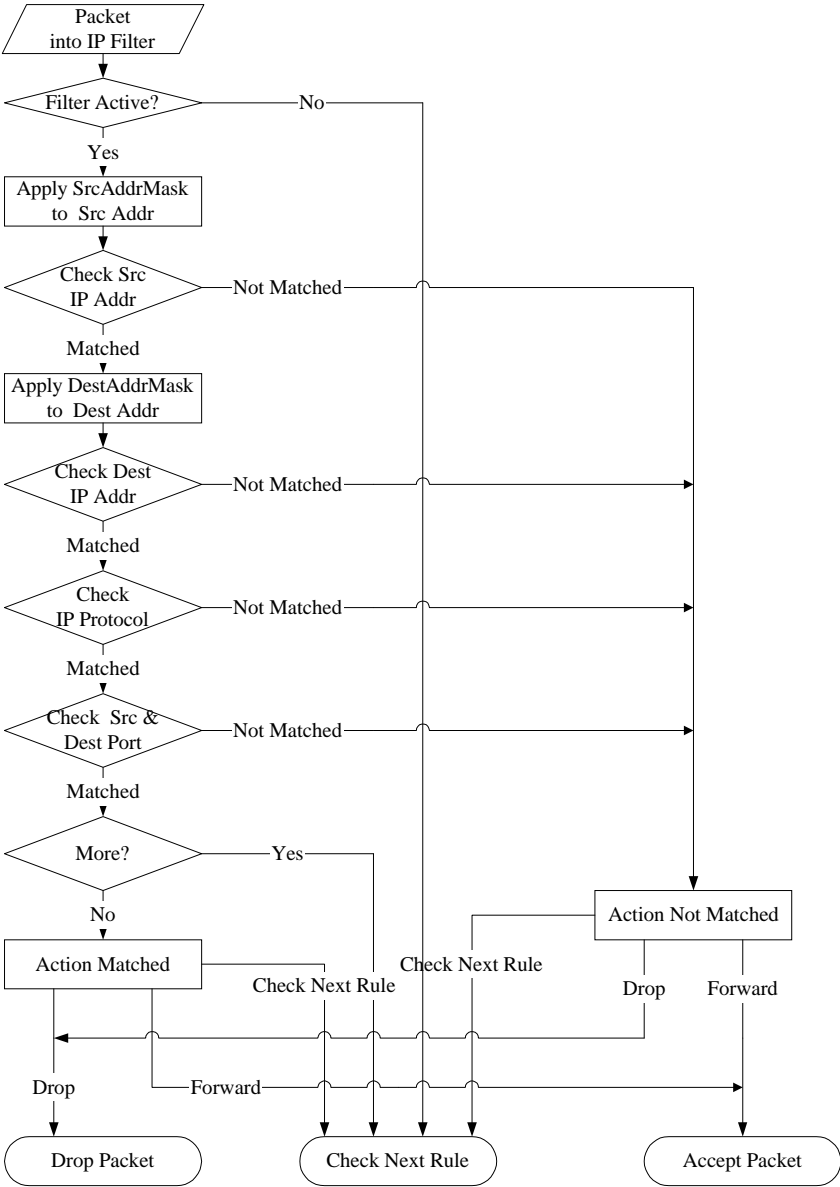

Figure 7-8 Executing an IP Filter

7.2.4 Generic Filter Rule

This section shows you how to configure a generic filter rule. The purpose of generic rules is to allow you to filter non-IP packets. For IP, it is generally easier to use the IP rules directly.

For generic rules, the Prestige treats a packet as a byte stream as opposed to an IP or IPX packet. You specify the portion of the packet to check with the Offset (from 0) and the Length fields, both in bytes. The Prestige applies the Mask (bit-wise ANDing) to the data portion before comparing the result against the Value to determine a match. The Mask and Value are specified in hexadecimal numbers. Note that it takes two hexadecimal digits to represent a byte, so if the length is 4, the value in either field will take 8 digits, e.g., FFFFFFFF.

To configure a generic rule, select Generic Filter Rule in the Filter Type field in the **Menu 21.4.1** and press [Enter] to open Generic Filter Rule, as shown below.

```
Menu 21.4.1 - Generic Filter Rule

Filter #: 4,1
Filter Type= Generic Filter Rule
Active= No
Offset= 0
Length= 0
Mask= N/A
Value= N/A
More= No           Log= None
Action Matched= Check Next Rule
Action Not Matched= Check Next Rule

Press ENTER to Confirm or ESC to Cancel:
Press Space Bar to Toggle.
```

Figure 7-9 **Menu 21.4.1 - Generic Filter Rule**

The following table describes the fields in the Generic Filter Rule Menu.

Table 7-5 Generic Filter Rule Menu Fields

Field	Description	Option
Filter #	This is the filter set, filter rule co-ordinates, i.e., 2,3 refers to the second filter set and the third rule of that set.	
Filter Type	Use the [SPACE BAR] to toggle between both types of rules. Parameters displayed below each type will be different.	Generic Filter Rule/ TCP/IP Filter Rule
Active	Select Yes to turn on the filter rule.	Yes/No
Offset	Enter the starting byte of the data portion in the packet that you wish to compare. The range for this field is from 0 to 255.	Default = 0
Length	Enter the byte count of the data portion in the packet that you wish to compare. The range for this field is 0 to 8.	Default = 0
Mask	Enter the mask (in Hexadecimal) to apply to the data portion before comparison.	
Value	Enter the value (in Hexadecimal) to compare with the data portion.	
More	If yes, a matching packet is passed to the next filter rule before an action is taken; else the packet is disposed of according to the action fields. If More is Yes, then Action Matched and Action Not Matched will be No.	Yes / No
Log	Select the logging option from the following: None – No packets will be logged. Action Matched - Only packets that match the rule parameters will be logged. Action Not Matched - Only packets that do not match the rule parameters will be logged. Both – All packets will be logged.	None Action Matched Action Not Matched Both
Action Matched	Select the action for a matching packet.	Check Next Rule Forward Drop
Action Not Matched	Select the action for a packet not matching the rule.	Check Next Rule Forward

	Drop
Once you have completed filling in Menu 21.4.1.1 - Generic Filter Rule, press [Enter] at the message [Press Enter to Confirm] to save your configuration, or press [Esc] to cancel. This data will now be displayed on Menu 21.1.1 - Filter Rules Summary.	

7.3 Example Filter

Let's design a filter to block outside users from telnetting and using FTP connections into the Prestige. Please see our Supporting CD for more example filters.

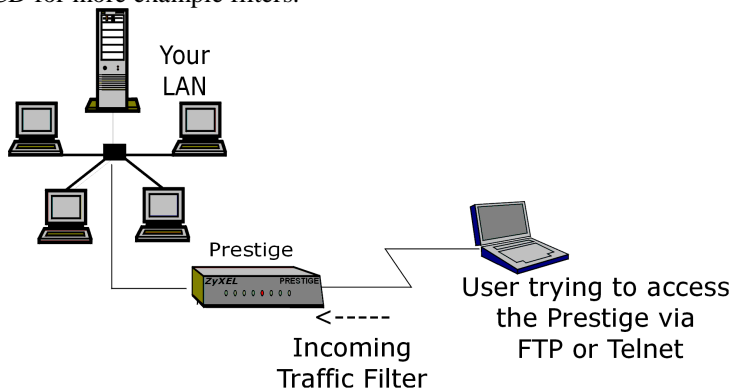

Figure 7-10 Filter Example

7.3.1 Before you begin

Before configuring a filter, you must know the following information:

1. **The inbound packet type (protocol & port number):** In this case, it is **TCP (06)** protocol with port **21** (FTP) and port **23** (Telnet).
2. **The source IP address:** In this case, as all connections from outside are blocked, the source IP is **0.0.0.0**.
3. **The destination IP address:** It is the Prestige's IP address if SUA is disabled and you have a static IP; otherwise enter **0.0.0.0** as the destination IP. Once 0.0.0.0 is set as the destination IP, Telnet and FTP connections are not allowed to reach the Prestige. For the LAN-to-LAN connection, you enter the Prestige's LAN IP as the destination IP in the filter rule. After the Telnet_WAN filter is applied to the remote node, it blocks the Telnet and FTP connections to the Prestige, but continues to permit FTP connection to the local FTP server.

7.3.2 Filter Configuration Steps

- Step 1.** Enter **21** from the Main Menu to open **Menu 21.1 - Filter Set Configuration**.
- Step 2.** Enter the index of the filter set you wish to configure (e.g., 3) and press [Enter].

- Step 3.** Enter a descriptive name or comment in the **Edit Comments** field (e.g., TELNET_WAN) and press [Enter].
- Step 4.** Press [Enter] at the message: [Press ENTER to confirm] to open **Menu 21.3.1 - Filter Rules Summary**.
- Step 5.** Enter **1** to configure the first filter rule. Make the entries in this menu as shown in the following figure.

```

Menu 21.3.1 - TCP/IP Filter Rule

Filter #: 3,1
Filter Type= TCP/IP Filter Rule
Active= Yes
IP Protocol= 6      IP Source Route= No
Destination: IP Addr= 0.0.0.0
              IP Mask= 0.0.0.0
              Port # = 20
              Port # Comp= Equal
Source:       IP Addr= 0.0.0.0
              IP Mask= 0.0.0.0
              Port # = 0
              Port # Comp= None

TCP Estab= No
More= No      Log= None
Action Matched= Drop
Action Not Matched= Forward

Press ENTER to Confirm or ESC to Cancel:
Press Space Bar to Toggle.
    
```

Press [SPACEBAR] to choose this filter rule type. The first filter rule type determines all subsequent filter types within a set.

Select **Yes** to make the rule active.

6 is the TCP protocol.

The port number for FTP is **21**. See RFC 1060 for port numbers of well-known services.

There are no more rules to check.

Select **Drop** here so that the packet will be dropped if its destination is the telnet port.

Select **Equal** here as we are looking for packets going to port 21 only.

Select **Next** here so that the next rule in this set will be checked.

Figure 7-11 Example Filter - Menu 21.3.1

When you press [Enter] to confirm, you will see the next screen. Note that there is only one filter rule in this set.

```
Menu 21.3 - Filter Rules Summary

# A Type                               Filter Rules                               M m n
-----
1 Y IP   Pr=6, SA=0.0.0.0, DA=0.0.0.0, DP=21   N D N
2 N
4 N
5 N
6 N

Enter Filter Rule Number (1-6) to Configure: 2
```

This shows you that you have configured and activated (**A = Y**) a TCP/IP filter rule (**Type = IP, Pr = 6**) for destination FTP ports (**DP = 21**).

M = N means an action can be taken immediately. The action is to drop the packet (**m = D**) if the action is matched and to forward the packet immediately (**n = N**) if the action is not matched and there are more rules to be checked (there is one more in this example).

Figure 7-12 Example Filter Rules Summary – Menu 21.3

Step 6. Enter 2 in the above menu to configure the second rule.. Configure this filter rule with port number as **23** (Telnet) as shown in the next screen (after you press [ENTER] to confirm).

Menu 21.5 - Filter Rules Summary				
#	A	Type	Filter Rules	M m n
1	Y	IP	Pr=6, SA=0.0.0.0, DA=0.0.0.0, DP=21	N D N
2	Y	IP	Pr=6, SA=0.0.0.0, DA=0.0.0.0, DP=23	N D F
3	N			
4	N			
5	N			
6	N			

Enter Filter Rule Number (1-6) to Configure:

Figure 7-13 Example Filter Rules Summary

After you've created the filter set, you must apply it.

Step 1. Enter **11** from the main menu to go to Menu 11.

Step 2. Go to the **Edit Filter Sets** field, press the [SPACEBAR] to toggle **Yes** to **No** and press [ENTER].

Step 3. This brings you to Menu 11.5. Apply the TELNET_FTP_WAN filter set (filter set 3) as shown in *Figure 7-16*.

7.4 Filter Types and SUA

There are two classes of filter rules, **Generic Filter** (Device) rules and Protocol Filter (**TCP/IP** and **IPX**) rules. Generic Filter rules act on the raw data from/to LAN and WAN. Protocol Filter rules act on the IP and IPX packets. Generic and TCP/IP filter rules are discussed in more detail in the next section. When SUA is enabled, the inside IP address and port number are replaced on a connection-by-connection basis, which makes it impossible to know the exact address and port on the wire. Therefore, the Prestige applies the protocol filters to the “native” IP address and port number before SUA for outgoing packets and after SUA for incoming packets. On the other hand, the generic, or device filters are applied to the raw packets that appear on the wire. They are applied at the point when the Prestige is receiving and sending the packets; i.e. the interface. The interface can be an Ethernet port or any other hardware port. The following diagram illustrates this.



Figure 7-14 Protocol and Device Filter Sets

7.5 Applying a Filter and Factory Defaults

This section shows you where to apply the filter(s) after you design it (them). Three sets of factory default filter rules have been configured in Menu 21 to prevent NetBIOS traffic from triggering calls and to prevent incoming telnetting.

7.5.1 LAN traffic

You seldom need to filter LAN traffic; however, the filter sets may be useful to block certain packets, reduce traffic and prevent security breaches. Go to **Menu 3.1** (shown below) and enter the number(s) of the filter set(s) that you want to apply as appropriate. You can choose up to four filter sets (from twelve) by entering their numbers separated by commas, e.g., 3, 4, 6, 11. Input filter sets filter incoming traffic to the Prestige and Output filter sets filter outgoing traffic from the Prestige. The factory default set, NetBIOS_LAN, is inserted in **protocol filters** –field under **Input Filter Sets** in **Menu 3.1** to block NetBIOS traffic to the Prestige from the LAN.

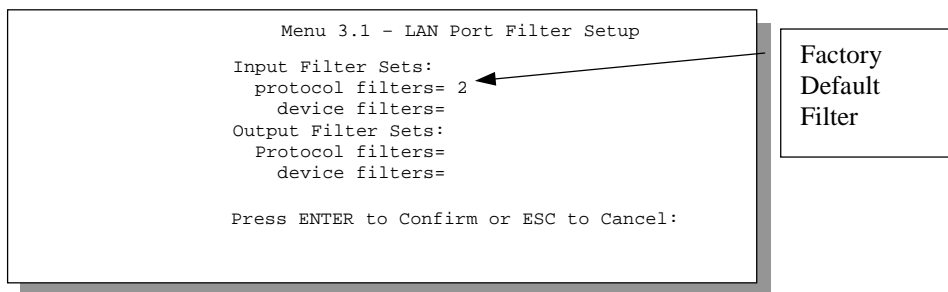

Figure 7-15 Filtering LAN Traffic

7.5.2 Remote Node Filters

Go to Menu 11.5 (shown below) and enter the number(s) of the filter set(s) as appropriate. You can cascade up to four filter sets by entering their numbers separated by commas. The factory default filter set, NetBIOS_WAN, is inserted in the **protocol filters** field under **Call Filter Sets** in Menu 11.5 to block local NetBIOS traffic from triggering calls to the ISP (when you are using **PPTP/PPPoE** encapsulation only). Filter set three, Telnet_FTP_WAN, blocks telnet and FTP connections from the WAN Port to help prevent security breaches.

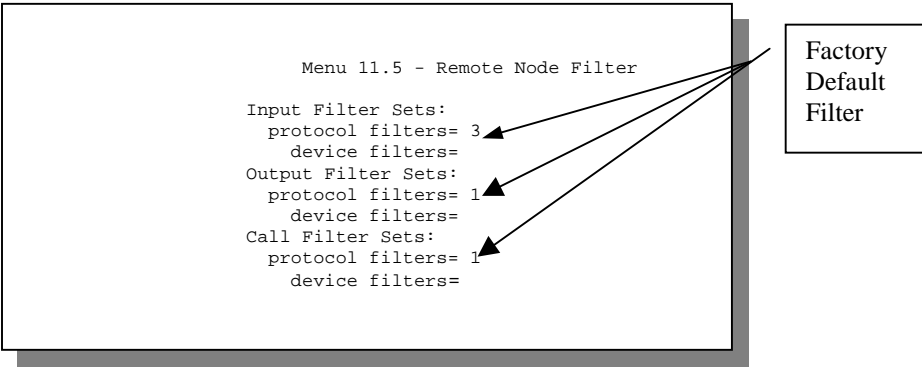

Figure 7-16 Filtering Remote Node Traffic

Chapter 8: SNMP Configuration

8.1 SNMP

SNMP (Simple Network Management Protocol) is a protocol used for exchanging management information between network devices. SNMP is a member of TCP/IP protocol suite. Your Prestige supports SNMP agent functionality, which allows a manager station to manage and monitor the Prestige through the network. The Prestige supports SNMP version one (SNMPv1).

Note: Keep in mind that SNMP is only available if TCP/IP is configured on your Prestige.

The next figure illustrates an SNMP management operation.

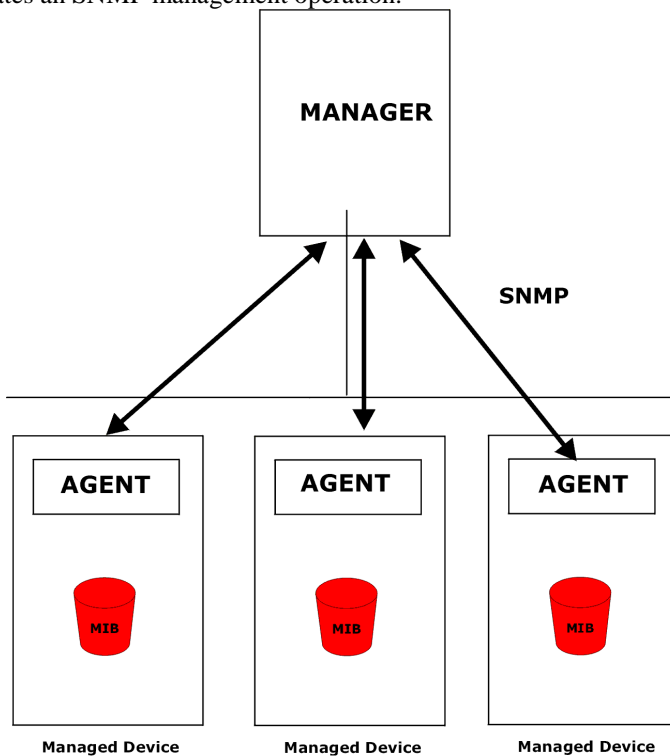

Figure 8-1 SNMP Management Model

An SNMP managed network consists of two main components: agents and manager.

An agent is a management software module that resides in a managed device . An agent translates the local management information from the managed device into a form compatible with SNMP. The manager is the console through which network administrators perform network management functions. It executes applications that control and monitor managed devices.

The managed devices contain object variables/managed objects that define each piece of information to be collected about a device. Examples of variables include such as number of packets received, node port status etc. A Management Information Base (MIB) is a collection of managed objects. SNMP allows manager and agents to communicate for the purpose of accessing these objects.

SNMP itself is a simple request/response protocol based on the manager/agent model. The manager issues a request and the agent returns responses using the following protocol operations:

Get

Allows the manager to retrieve an object variable from the agent.

GetNext

Allows the manager to retrieve the next object variable from a table or list within an agent. In SNMPv1, when a manager wants to retrieve all elements of a table from an agent, it initiates a Get operation, followed by a series of GetNext operations.

Set

Allows the manager to set values for object variables within an agent.

Trap

Used by the agent to inform the manager of some events.

8.1.1 SNMP Configuration

To configure SNMP, select option **22. SNMP Configuration** from the Main Menu to open Menu 22 - SNMP Configuration, as shown in the figure. The “community” for Get, Set and Trap fields is simply SNMP’s terminology for password.

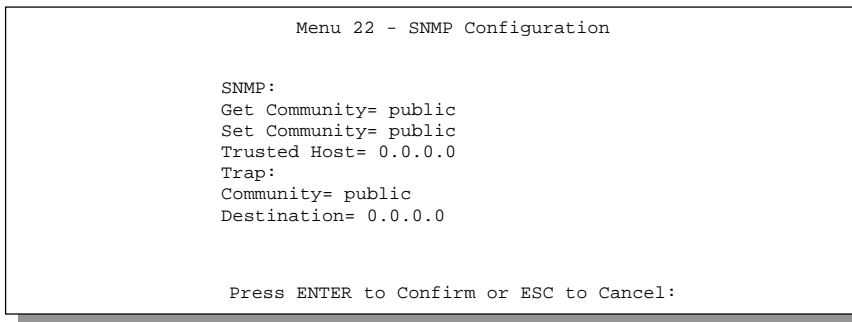

Figure 8-2 Menu 22 - SNMP Configuration

The following table describes the SNMP configuration parameters.

Table 8-1 SNMP Configuration Menu Fields

Field	Description	Option
Get Community	Enter the Get Community, which is the password for the incoming Get- and GetNext- requests from the management station.	Public
Set Community	Enter the set community, which is the password for incoming Set- requests from the management station.	Public
Trusted Host	If you enter a trusted host, your Prestige will only respond to SNMP messages from this address. If you leave the field blank (default), your Prestige will respond to all SNMP messages it receives, regardless of source.	Blank
Trap: Community	Enter the trap community, which is the password sent with each trap to the SNMP manager.	Public
Trap: Destination	Enter the IP address of the station to send your SNMP traps to.	Blank
Once you have completed filling in Menu 22 - SNMP Configuration, press [ENTER] at the message [Press ENTER to Confirm...] to save your configuration, or press [ESC] to cancel.		

Chapter 9: System Information & Diagnosis

This chapter talks you through SMT Menus 24.1 to 24.4.

This chapter covers the diagnostic tools that help you to maintain your Prestige. These tools include updates on system status, port status, log and trace capabilities and upgrades for the system software. This chapter describes how to use these tools in detail.

Select menu 24 in the main menu to open **Menu 24 - System Maintenance**, as shown below.

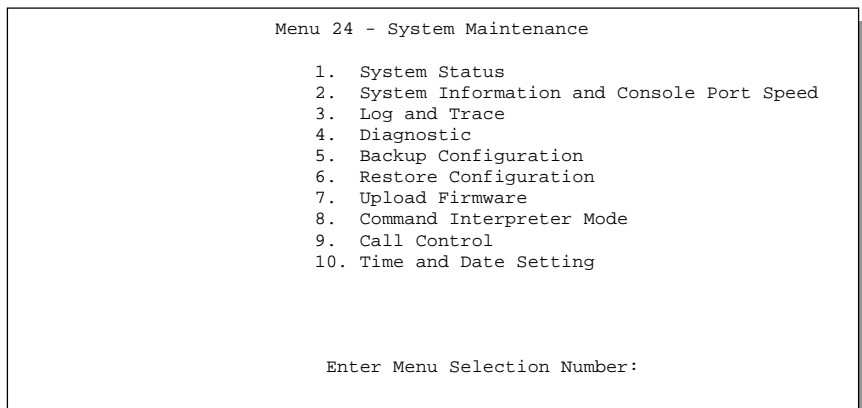

Figure 9-1 **Menu 24 - System Maintenance**

9.1 System Status

The first selection, System Status, gives you information on the version of your system firmware and the status and statistics of the ports, as shown in the figure below. System Status is a tool that can be used to monitor your Prestige. Specifically, it gives you information on your system firmware version, number of packets sent and number of packets received.

To get to the System Status:

- Step 1.** Enter number 24 to go to Menu 24 - System Maintenance.
- Step 2.** In this menu, enter number 1 to open **System Maintenance - Status**.
- Step 3.** There are three commands in **Menu 24.1 - System Maintenance - Status**. Entering 1 drops the WAN (PPTP/PPPoE) connection, 9 resets the counters and [Esc] takes you back to the previous screen.

The table below describes the fields present in **Menu 24.1 - System Maintenance - Status**. It should be noted that these fields are READ-ONLY and are meant to be used for diagnostic purposes.

```

Menu 24.1 -- System Maintenance - Status
                                                    1:39:06
                                                    Thus. Jan. 1. 1970
Port  Status      TxPkts    RxPkts    Cols    Tx B/s    Rx B/s    Up Time
WAN   Down          1         0         0        0         0         0:00:00
LAN   Down          0         0         0        0         0         0:00:00

Port:      Ethernet Address    IP Address          IP Mask    DHCP
WAN        00:a0:c5:21:8c:a3    0.0.0.0            0.0.0.0    Client
LAN        00:a0:c5:21:8c:a2    192.168.1.1       255.255.255.0  Server

System up Time:      1:08:22

Name: P310.www.zyxel.com
Routing: IP
ZyNOS F/W Version: V.251 : 2/17/2000

Press Command:

COMMANDS: 1-Drop WAN 9-Reset Counters  ESC-Exit
    
```

Figure 9-2 Menu 24.1 - System Maintenance – Status

The following table describes the fields present in **Menu 24.1 - System Maintenance - Status**.

Table 9-1 System Maintenance - Status Menu Fields

Field	Description
Port	The WAN or LAN port.
Status	Shows the port speed and duplex setting if you're using Ethernet Encapsulation and down (line is down), idle (line (ppp) idle), dial (starting to trigger a call) and drop (dropping a call) if you're using PPPoE Encapsulation.
TxPkts	The number of transmitted packets on this port.
RxPkts	The number of received packets on this port.
Cols	The number of collisions on this port.
Tx B/s	Shows the transmission speed in Bytes per second on this port.
Rx B/s	Shows the reception speed in Bytes per second on this port.
Up Time	Total amount of time the line has been up.
LAN	
Ethernet Address	The LAN port Ethernet address.
IP Address	The LAN port IP address.
IP Mask	The LAN port IP mask.
DHCP	The LAN port DHCP role.
WAN	
Ethernet Address	The WAN port Ethernet address.
IP Address	The WAN port IP address.
IP Mask	The WAN port IP mask.
DHCP	The WAN port DHCP role.
System up Time	The total time the Prestige has been on.
Name	This is the Prestige's system name + domain name assigned in Menu 1. E.G., System Name= p310; Domain Name= www.zyxel.com Name= p310.www.zyxel.com
ZyNOS F/W Version	The ZyNOS Firmware version and the date created.

9.2 System Information and Console Port Speed

This section describes your system and allows you to choose different console port speeds. To get to the System Information and Console Port Speed:

- Step 1.** Enter **24** to go to **Menu 24 – System Maintenance**.
- Step 2.** Enter **2** to open, **Menu 24.2 - System Information and Console Port Speed**.
- Step 3.** From this Menu you have two choices as shown in the next figure:

```
Menu 24.2 - System Information and Console Port Speed

1. System Information
2. Console Port Speed

Please enter selection:
```

Figure 9-3 Menu 24.2 – System Information and Console Port Speed

9.2.1 System Information

System Information gives you information about your system as shown below. More specifically, it gives you information on your routing protocol, country code, Ethernet address, IP address, etc.

```
Menu 24.2.1 - System Maintenance - Information
Name: P310.www.zyxel.com
Routing: IP
ZyNOS F/W Version: V2.51 | 2/17/2000

LAN
Ethernet Address: 00:a0:c5:21:8c:a2
IP Address: 192.168.1.10
IP Mask: 255.255.255.0
DHCP: Server

Press ESC or RETURN to Exit
```

Figure 9-4 Menu 24.2.1 System Maintenance - Information

Table 9-2 Fields in System Maintenance

Field	Description
Name	This is the Prestige's system name + domain name assigned in Menu 1. E.G., System Name= Prestige; Domain Name= zyxel.com Name= P310. zyxel.com
Routing	Refers to the routing protocol used.
ZyNOS F/W Version	Refers to the version of ZyXEL's Network Operating System software.
Ethernet Address	Refers to the Ethernet MAC (Media Access Control) address of your Prestige.
IP Address	This is the IP address of the Prestige in dotted decimal notation.
IP Mask	This shows the subnet mask of the Prestige.
DHCP	This field shows the DHCP setting of the Prestige.

9.2.2 Console Port Speed

You can change the speed of the console port through **Menu 24.2.2 – Console Port Speed**. Your Prestige supports 9600 (default), 19200, 38400, 57600, and 115200 bps for the console port. Use the [SPACE BAR] to select the desired speed in **Menu 24.2.2**, as shown below.

```

Menu 24.2.2 - System Maintenance - Change Console Port Speed

Console Port Speed: 115200

Press ENTER to Confirm or ESC to Cancel:
Press Space Bar to Toggle.

```

Figure 9-5 Menu 24.2.2 – System Maintenance – Change Console Port Speed

9.3 Log and Trace

There are three logging facilities in the Prestige. The first is the error logs and trace records that are stored locally. The second is the UNIX syslog facility for message logging. The third logging facility- Call-Triggering Packet is also stored locally.

9.3.1 Viewing Error Log

The first place you should look for clues when something goes wrong is the error/trace log. Follow the procedure below to view the local error/trace log:

Step 1. Select option 24 from the Main Menu to open **Menu 24 - System Maintenance**.

Step 2. From Menu 24, select option 3 to open **Menu 24.3 - System Maintenance - Log and Trace**.

Step 3. Select the first option from **Menu 24.3 - System Maintenance - Log and Trace** to display the error log in the system.

After the Prestige finishes displaying, you will have the option to clear the error log.

```
Menu 24.3 - System Maintenance - Log and Trace

1. View Error Log
2. UNIX Syslog

4. Call-Triggering Packet

Please enter selection
```

Figure 9-6 Examples of Error and Information Messages

Examples of typical error and information messages are presented in the figure below.

```
59 Thu Jan 1 00:00:03 1970 PINI INFO SMT Session Begin
60 Thu Jan 1 00:05:11 1970 PINI INFO SMT Session End
61 Thu Jan 1 00:17:59 1970 PINI INFO SMT Session Begin
62 Thu Jan 1 00:24:40 1970 PINI INFO SMT Session End
63 Thu Jan 1 00:35:32 1970 PINI INFO SMT Session Begin
Clear Error Log (y/n):
```

Figure 9-7 Examples of Error and Information Messages

9.3.2 UNIX Syslog

The Prestige uses the UNIX syslog facility to log the CDR (Call Detail Record) and system messages to a syslog server. Syslog and accounting can be configured in **Menu 24.3.2 - System Maintenance - Syslog and Accounting**, as shown next.

```

Menu 24.3.2 -- System Maintenance - UNIX Syslog and Accounting

UNIX Syslog:
Active= No
Syslog IP Address= ?
Log Facility= Local 1

Types:
CDR= No
Packet triggered= No
Filter log= No
PPP log= No
Press ENTER to Confirm or ESC to Cancel:
Press Space Bar to Toggle.
    
```

Figure 9-8 Menu 24.3.2 - System Maintenance – UNIX Syslog

You need to configure the UNIX syslog parameters described in the following table to activate syslog then choose what you want to log.

Table 9-3 System Maintenance Menu Syslog Parameters

Parameter	Description
UNIX Syslog: Active	Press the [SPACE BAR] to turn on or off syslog.
Syslog IP Address	Enter the IP Address of the server that will log the CDR (Call Detail Record) and system messages i.e., the syslog server.
Log Facility	Press the [SPACE BAR] to toggle between the 7 different Local options. The log facility allows you to log the message to different files in the server. Please refer to your UNIX manual for more detail.
Types: CDR	Call Detail Record (CDR) logs all data phone line activity if set to Yes.
Packet triggered	The first 48 bytes or octets and protocol type of the triggering packet is sent to the UNIX syslog server when this field is set to Yes.
Filter log	No filters are logged when this field is set to No. Filters with the individual filter Log Filter field set to Yes (Menu 21.x.x.) are logged when this field is set to Yes.
PPP log	PPP events are logged when this field is set to Yes.

Your Prestige sends four types of syslog messages. Some examples (not P310 specific) of these syslog messages with their message formats are shown next:

CDR

CDR Message Format
<pre>SdcmSyslogSend(SYSLOG_CDR, SYSLOG_INFO, String); String = board xx line xx channel xx, call xx, str board = the hardware board ID line = the WAN ID in a board Channel = channel ID within the WAN call = the call reference number which starts from 1 and increments by 1 for each new call str = C01 Outgoing Call dev xx ch xx (dev:device No. ch:channel No.) L02 Tunnel Connected(L2TP) C02 OutCall Connected xxxx (means connected speed) xxxxx (means Remote Call Number) L02 Call Terminated C02 Call Terminated</pre>

```
Jul 19 11:19:27 192.168.102.2 ZyXEL: board 0 line 0 channel 0, call 1, C01 Outgoing Call
dev=2 ch=0 40002
Jul 19 11:19:32 192.168.102.2 ZyXEL: board 0 line 0 channel 0, call 1, C02 OutCall
Connected 64000 40002
Jul 19 11:20:06 192.168.102.2 ZyXEL: board 0 line 0 channel 0, call 1, C02 Call Terminated
```

1. Packet triggered

Packet triggered Message Format
<pre>sdcmdSyslogSend(SYSLOG_PKTTRI, SYSLOG_NOTICE, String); String = Packet trigger: Protocol=xx Data=xxxxxxxxx.....x Protocol: (1:IP 2:IPX 3:IPXHC 4:BPDU 5:ATALK 6:IPNG) Data: We will send forty-eight Hex characters to the server</pre>

```
Jul 19 11:28:39 192.168.102.2 ZyXEL Communications Corp.: Packet Trigger: Protocol=1,
Data=4500003c100100001f010004c0a86614ca849a7b08004a5c020001006162636465666768696a6b6c6d6e6f
7071727374
Jul 19 11:28:56 192.168.102.2 ZyXEL Communications Corp.: Packet Trigger: Protocol=1,
Data=4500002c1b0140001f06b50ec0a86614ca849a7b0427001700195b3e00000000600220008cd40000020405
b4
```

2. Filter log

Filter log Message Format
<pre>SdcmSyslogSend(SYSLOG_FILLOG, SYSLOG_NOTICE, String); String = IP[Src=xx.xx.xx.xx Dst=xx.xx.xx.xx prot spo=xxxxx dpo=xxxxx] S04>R01mD IP[...] is the packet header and S04>R01mD means filter set 4 (S) and rule 1 (R), match (m) drop (D). Src: Source Address Dst: Destination Address prot: Protocol ("TCP","UDP","ICMP") spo: Source port dpo: Destination port</pre>

```
Jul 19 14:44:00 192.168.102.2 ZyXEL Communications Corp.: IP[Src=192.168.102.20
Dst=202.132.154.1 UDP spo=01170 dpo=00057]}S03>R01mF
```

Jul 19 14:44:04 192.168.102.2 ZyXEL Communications Corp.: IP[Src=192.168.102.20
Dst=202.132.154.1 ICMP]}S03>R01mF

3. PPP log

PPP Log Message Format

<pre>sdcmdSyslogSend(SYSLOG_PPPLOG, SYSLOG_NOTICE, String); String = ppp:Proto Starting / ppp:Proto Opening / ppp:Proto Closing / ppp:Proto Shutdown Proto = LCP / ATCP / BACP / BCP / CBCP / CCP / CHAP/ PAP / IPCP / IPXCP</pre>
--

Jul 19 11:42:44 192.168.102.2 ZyXEL Communications Corp.: ppp:LCP Closing
Jul 19 11:42:49 192.168.102.2 ZyXEL Communications Corp.: ppp:IPCP Closing
Jul 19 11:42:54 192.168.102.2 ZyXEL Communications Corp.: ppp:CCP Closing

9.3.3 Call-Triggering Packet

Call-Triggering Packet displays information about the packet that triggered dial-out call in an easy readable format. Equivalent information is available in **Menu 24.1** but in hex format. An example is shown next.

```
IP Frame: ENET0-RCV Size: 44/ 44   Time: 17:02:44.262
Frame Type:

IP Header:
IP Version           = 4
Header Length       = 20
Type of Service     = 0x00 (0)
Total Length        = 0x002C (44)
Identification      = 0x0002 (2)
Flags               = 0x00
Fragment Offset     = 0x00
Time to Live        = 0xFE (254)
Protocol            = 0x06 (TCP)
Header Checksum     = 0xFB20 (64288)
Source IP           = 0xC0A80101 (192.168.1.1)
Destination IP      = 0x00000000 (0.0.0.0)

TCP Header:
Source Port         = 0x0401 (1025)
Destination Port    = 0x000D (13)
Sequence Number     = 0x05B8D000 (95997952)
Ack Number          = 0x00000000 (0)
Header Length       = 24
Flags               = 0x02 (...S.)
Window Size         = 0x2000 (8192)
Checksum            = 0xE06A (57450)
Urgent Ptr          = 0x0000 (0)
Options             =
    0000: 02 04 02 00

RAW DATA:
0000: 45 00 00 2C 00 02 00 00 00-FE 06 FB 20 C0 A8 01 01  E.....
0010: 00 00 00 00 04 01 00 0D-05 B8 D0 00 00 00 00  .....
0020: 60 02 20 00 E0 6A 00 00-02 04 02 00

Press any key to continue...
```

Figure 9-9 Call-Triggering Packet Example

9.4 Diagnostic

The diagnostic facility allows you to test the different aspects of your Prestige to determine if it is working properly. **Menu 24.4** allows you to choose among various types of diagnostic tests to evaluate your system, as shown next.

```
Menu 24.4 - System Maintenance - Diagnostic

TCP/IP
1. Ping Host
2. WAN DHCP Release
3. WAN DHCP Renewal
4. Internet Setup Test

System
11. Reboot System

Enter Menu Selection Number:

Host IP Address= N/A
```

Figure 9-10 Menu 24.4 - System Maintenance - Diagnostic

Follow the procedure below to get to **Menu 24.4 - System Maintenance – Diagnostic**.

Step 1. From the Main Menu, select option 24 to open **Menu 24 - System Maintenance**.

Step 2. From this menu, select option 4. Diagnostic. This will open **Menu 24.4 - System Maintenance - Diagnostic**.

9.4.1 WAN DHCP

DHCP functionality can be enabled on the LAN or WAN as shown in *Figure 9-11*. LAN DHCP has already been discussed in *section 3.1.5*. The Prestige can act either as a WAN DHCP client (**IP Address Assignment** field in Menu 4 or Menu 11.3 is **Dynamic** and the **Encapsulation** field in Menu 4 or Menu 11 is **Ethernet**) or “none”, i.e., you have a static IP. The WAN Release and Renewal fields in Menu 24.4 conveniently allow you to release and/or renew the assigned WAN IP address, subnet mask and default gateway in a fashion similar to winipcfg.

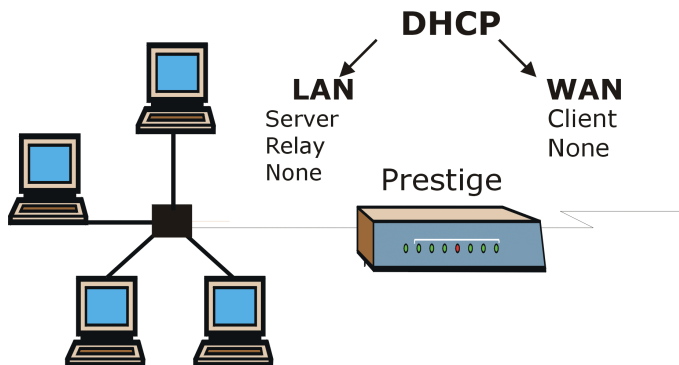

Figure 9-11 WAN & LAN DHCP

The following table describes the diagnostic tests available in **Menu 24.4** for your Prestige and the connections.

Table 9-4 System Maintenance Menu Diagnostic

Number	Field	Description
1	Ping Host	Enter 1 to ping any machine (with an IP address) on your LAN or WAN. Enter its IP address in the Host IP Address= field mentioned in the last row of this table.
2	WAN DHCP Release	Enter 2 to release your WAN DHCP settings.
3	WAN DHCP Renewal	Enter 3 to renew your WAN DHCP settings. The renewal timeout is 32 seconds.
4	Internet Setup Test	Enter 4 to test the Internet Setup. You can also test the Internet Setup in Menu 4 - Internet Access. Please refer to the chapter- <i>Internet Access</i> for more details.
11	Reboot System	Enter 11 to reboot the Prestige.
	Host IP Address=	If you entered 1 above, then enter the IP address of the machine you want to ping in this field.

Chapter 10: Transferring Files

This chapter tells you how to back up and restore your configuration file as well as upload new firmware and a new configuration file.

10.1 Filename conventions

The configuration file (often called the romfile or rom-0) contains the factory default settings in the menus such as password, DHCP Setup, TCP/IP Setup etc. It arrives from ZyXEL with a name of prestige.ROM or similar. Once you have customized the Prestige's setting, they can be saved back to PC/workstation under a filename of your choosing. Choose something meaningful, e.g., "prestige.cfg".

The ZyNOS firmware file (sometimes referred to as the ras file) is the file that contains the ZyXEL Network Operating System firmware and usually is the Prestige model name with a *.bin extension, e.g., prestige.bin. With serial (XMODEM) transfer, the filenames on the PC are your choice. With many ftp and tftp clients, they are as well as seen next.

```
ftp>put prestige.bin ras
```

This is a sample ftp session showing the transfer of the file "prestige.bin" on your computer to the Prestige and renaming it "ras".

```
ftp>get rom-0 prestige.cfg
```

This is a sample ftp session saving the current Prestige configuration to the file prestige.cfg on your computer.

If your [t]ftp client does *not* allow you have a destination filename different than the source, you will need to rename them as the Prestige only recognizes "rom-0" and "ras". Be sure you keep unaltered copies of both files for later use.

The following table is a summary. Please note that the internal filename refers to the filename on the Prestige and the external filename refers to the filename not on the Prestige, i.e., on your workstation, local network or ftp site and so the name (but not the extension) will vary. The AT command is the command you enter after you press "Y" when prompted in the SMT menu to go into debug mode. After uploading new firmware see the **ZyNOS F/W Version** field in **Menu 24.2.1** (Figure 9-4 Menu 24.2.1 System Maintenance - Information) to check you have uploaded the correct firmware version.

Table 10-1 Filename Conventions

File Type	Internal Name	External Name	Description	AT Command
Configuration File	Rom-0	*.rom	This is the router configuration filename on the Prestige. Uploading the rom-0 file replaces the entire ROM file system, including your Prestige configurations, system-related data (including the baud rate and default password), the error log and the trace log.	ATLC
Firmware	Ras	*.bin	This is the generic name for the ZyNOS firmware on the Prestige.	ATUR

10.1.1 Firmware Development

It is important to upgrade your firmware regularly, especially if there are problems. If you discover an unexpected behavior, or bug, see if your problem is mentioned in the release notes. Load it according to instructions (e.g., see if the default configuration file is needed also). If the problem still exists, e-mail or call tech support.

10.2 Backup Configuration

The Prestige displays DIFFERENT messages explaining different ways to backup, restore and upload files in Menu 24.5, 24.6, 24.7.1 and 24.7.2 when you use the serial/console port and when you telnet in.

Option 5 from **Menu 24 - System Maintenance** allows you to backup the current Prestige configuration to your workstation. Backup is highly recommended once your Prestige is functioning properly. FTP and TFTP are the preferred methods for backing up your current workstation configuration to your computer since FTP and TFTP are faster. You can also perform backup and restore using menu 24 through the console port. Any serial communications program should work fine; however, you must use the XMODEM protocol to perform the download/upload and you don't have to rename the files (*see section 10.1*). Please note that terms "download" and "upload" are relative to the workstation. Download means to transfer from another machine to the workstation, while upload means from your workstation to another machine.

```

Menu 24.5 -- System Maintenance - Backup Configuration

Ready to backup Configuration via Xmodem.
Do you want to continue (y/n):
    
```

Figure 10-1 Menu 24.5 - System Maintenance - Backup Configuration (via console port)

- Step 1.** Go to menu 24.5.
- Step 2.** Press “Y” to indicate that you want to continue. The following procedure is for the HyperTerminal program. The procedure for other serial communications programs should be similar.
- Step 3.** Click “Transfer” in the HyperTerminal menu bar, then “Receive File” from the drop-down menu to display the following screen. Follow the instructions as shown.

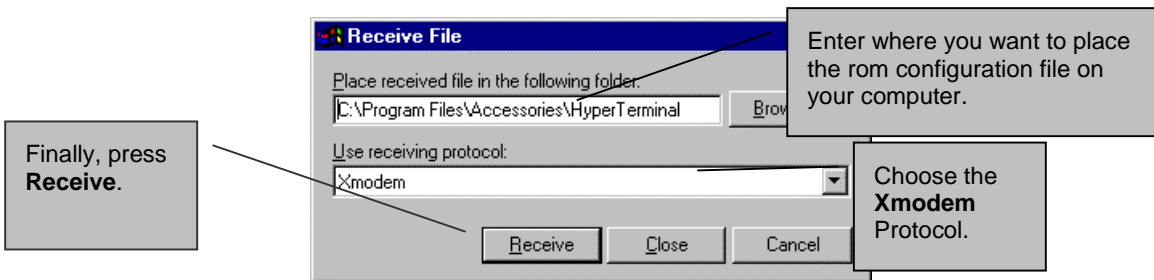

Figure 10-2 Backup Example Using HyperTerminal

- Step 4.** After a successful backup you will see the following screen. Press any key to return to the SMT menu

```

** Backup Configuration completed. OK.
### Hit any key to continue.###
    
```

Figure 10-3 Successful Backup Confirmation Screen

```
Menu 24.5 -- System Maintenance - Backup Configuration

To transfer the configuration file to your workstation, follow the procedure
below:

1. Launch the FTP client on your workstation.
2. Type "open" and the IP address of your router. Then type "root" and
SMT password as requested.
3. Locate the 'rom-0' file.
4. Type 'get rom-0' to back up the current router configuration to
your workstation.

For details on FTP commands, please consult the documentation of your FTP
client program. For details on backup using TFTP (note that you must remain
in this menu to back up using TFTP), please see your router manual.

Press ENTER to Exit:
```

Figure 10-4 Telnet into Menu 24.5

For details about backup using TFTP please refer to the section on *TFTP File Transfer*.

10.3 Restore Configuration

Menu 24.6 -- System Maintenance - Restore Configuration allows you to restore the configuration via the console port. Note that this function erases the current configuration before restoring to the previous back up configuration; please do not attempt to restore unless you have the a backup configuration stored on disk. FTP and TFTP are the preferred methods for restoring your current workstation configuration to your Prestige since FTP and TFTP are faster. Please note that the system reboots automatically after the file transfer is complete.

```
Menu 24.6 -- System Maintenance - Restore Configuration

Ready to restore Configuration via Xmodem.
Do you want to continue (y/n):
```

Figure 10-5 Menu 24.6 - System Maintenance - Restore Configuration (via console port)

- Step 1.** Go to menu 24.6.
- Step 2.** Press “Y” to indicate that you want to continue. Follow the procedure as shown previously for the HyperTerminal program. The procedure for other serial communications programs should be similar.
- Step 3.** Click “Transfer” in the HyperTerminal menu bar, then “Send File” from the drop-down menu.
- Step 4.** Enter where the rom configuration file is on your computer, and make sure you choose the X-Modem Protocol. Then press “Send”.

Step 5. After a successful restoration you will see the following screen. Press any key to return to reboot the system.

```
Save to ROM
Hit any key to start system reboot.
```

Figure 10-6 Successful Restoration Confirmation Screen

```
Menu 24.6 -- System Maintenance - Restore Configuration

To transfer the firmware and configuration file to your workstation, follow the
procedure below:

1. Launch the FTP client on your workstation.
2. Type "open" and the IP address of your router. Then type "root" and
SMT password as requested.
3. Type "put backupfilename rom-0" where backupfilename is the name of
your backup configuration file on your workstation and rom-spt is the
remote file name on the router. This restores the configuration to
your router.
4. The system reboots automatically after a successful file transfer

For details on FTP commands, please consult the documentation of your FTP
client program. For details on backup using TFTP (note that you must remain
in this menu to back up using TFTP), please see your router manual.

Press ENTER to Exit:
```

Figure 10-7 Telnet into Menu 24.6

For details about restoring firmware and configuration files using TFTP please refer to the section on *TFTP File Transfer*.

10.4 Upload Firmware

Menu 24.7 -- System Maintenance - Upload Firmware allows you to upgrade the firmware and the configuration file via the console port. Note that this function erases the old data before installing the new one; please do not attempt to update unless you have the new firmware at hand. There are two components in the system: the router firmware and the configuration file, as shown below.

```
Menu 24.7 -- System Maintenance - Upload Firmware

1. Upload Router Firmware
2. Upload Router Configuration File

Enter Menu Selection Number:
```

Figure 10-8 Menu 24.7 - System Maintenance - Upload Firmware

10.4.1 Upload Router Firmware via the Console Port

FTP or TFTP are the preferred methods for uploading router firmware to your Prestige. However in the event of your network being down, uploading router firmware is only possible with a direct connection to your Prestige via the console port. Uploading router firmware via the console port under normal conditions is not recommended since FTP or TFTP is faster. Any serial communications program should work fine; however, you must use the XMODEM protocol to perform the download/upload.

Select 1 from **Menu 24.7 – System Maintenance – Upload Firmware** to go to **Menu 24.7.1 - System Maintenance - Upload Router Firmware**, then follow the instructions as shown in the following screen

```
Menu 24.7.1 - System Maintenance - Upload Router Firmware

To upload router firmware:
1. Enter "y" at the prompt below to go into debug mode.
2. Enter "atur" after "Enter Debug Mode" message.
3. Wait for "Starting XMODEM upload" message before activating
   Xmodem upload on your terminal.
4. After successful firmware upload, enter "atgo" to restart the
   router.

Warning: Proceeding with the upload will erase the current router
firmware.

Do You Wish To Proceed:(Y/N)
```

Figure 10-9 Menu 24.7.1 - System Maintenance - Upload Router Firmware

After the "Starting XMODEM upload" message appears, activate the Xmodem protocol on your computer. Follow the procedure as shown previously for the HyperTerminal program. The procedure for other serial communications programs should be similar.

- Step 1** Click "Transfer" in the HyperTerminal menu bar, then "Send File" from the drop-down menu.
- Step 2** Enter the path and name of the firmware file (*.bin extension) on your computer.
- Step 3** Choose the **Xmodem** Protocol.
- Step 4** Finally, press **Send**.
- Step 5** The system reboots automatically after a successful firmware upload.

10.4.2 Upload Router Firmware using FTP

To transfer the firmware, follow the instructions as shown in the following screen (Menu 24.7.1 using Telnet).

```

Menu 24.7.1 - Upload Router Firmware using FTP
To upload the router firmware, follow the procedure below:
1. Launch the FTP client on your workstation.
2. Type "open" and the IP address of your Prestige. Then type "root" and your SMT password as requested.
3. Type "put firmwarefilename ras" where "firmwarefilename" is the name of your firmware upgrade file on your workstation and "ras" is the remote file name on the Prestige.
4. The system reboots automatically after a successful firmware upload.
For details on FTP commands, please consult the documentation of your FTP client program. For details on uploading router firmware using TFTP (note that you must remain in menu 24.7.1 to upload router firmware using TFTP), please see the Prestige manual.

Press ENTER to Exit:

```

Figure 10-10 Menu 24.7.1 as seen using Telnet

1.1.1 Example - Using the FTP command from the DOS Prompt

Use "put" to transfer files from the workstation to the Prestige, e.g., `put prestige.bin ras` transfers the firmware on your computer (`prestige.bin`) to the Prestige and renames it "ras". Similarly `put prestige.rom rom-0` transfers the configuration file on your computer (`prestige.rom`) to the Prestige and renames it "rom-0". See the beginning of this chapter for more information on filenames. Type "quit" to exit the ftp prompt.

```

331 Enter PASS command
Password:
230 Logged in
ftp> bin
200 Type I OK
ftp> put prestige.bin ras
200 Port command okay
150 Opening data connection for STOR ras
226 File received OK
ftp: 327680 bytes sent in 1.10Seconds 297.89Kbytes/sec.
ftp> quit

```

Figure 10-11 FTP Session Example

Note: The system reboots after a successful upload.

The following table describes some of the fields that you may see in third party FTP clients:

Table 10-2 Third Party FTP Clients –General fields

Host Address	Enter the address of the host server.
Login Type	<ul style="list-style-type: none"> Anonymous.

	<p>This is when a user I.D. and password is automatically supplied to the server for anonymous access. Anonymous logins will work only if your ISP or service administrator has enabled this option.</p> <ul style="list-style-type: none"> • Normal. <p>The server requires a unique User ID and Password to login.</p>
Transfer Type	Transfer files in either ASCII (plain text format) or in binary mode.
Initial Remote Directory.	Specify the default remote directory (path).
Initial Local Directory.	Specify the default local directory (path).

1.1.1 Upload Router Firmware using TFTP

Even though TFTP should work over WAN as well, it is not recommended.

To use TFTP, your workstation must have both telnet and TFTP clients. To update your firmware, follow the procedure below.

- Step 1.** Use telnet from your workstation to connect to the Prestige and log in. Because TFTP does not have any security checks, the Prestige records the IP address of the telnet client and accepts TFTP requests only from this address.
- Step 2.** Put the SMT in Command Interpreter (CI) mode by entering **8** in **Menu 24 – System Maintenance**.
- Step 3.** Enter command “`sys stdio 0`” to disable the SMT timeout, so the TFTP transfer will not be interrupted. Enter command “`sys stdio 5`” to restore the five-minute SMT timeout (default) when the file transfer is complete.
- Step 4.** Launch the TFTP client on your workstation and connect to the Prestige.
- Step 5.** Go to SMT menu 24.7.1. Note that you must remain in this menu until file transfer is complete.
- Step 6.** Use the TFTP client to transfer files between the Prestige and the workstation.
- Step 7.** Specify “ras” as the remote filename if you want to upload firmware from your workstation into the Prestige.
- Step 8.** The system reboots automatically after a successful firmware upload.

Note that the telnet connection must be active and the SMT in CI mode before and during the TFTP transfer. TFTP and FTP over WAN will not work if you have applied a filter in Menu 11.5 to block Telnet service from the WAN.

For details on TFTP commands, please consult the documentation of your TFTP client program. For UNIX, use “put” to transfer from the workstation to the Prestige, and “binary” to set binary transfer mode.

1.1.2 Example Using TFTP To Upload Prestige Firmware

The following is an example tftp command:

```
TFTP [-i] host put prestige.bin ras
```

where “i” specifies binary image transfer mode (use this mode when transferring binary files), “host” is the Prestige IP address, “put” transfers the file source on the workstation (prestige.bin – name of the firmware on your computer) to the file destination on the remote host (ras - name of the firmware on the Prestige).

The following table describes some of the fields that you may see in third party TFTP clients.

Table 10-3 Third Party TFTP Clients –General fields

Host	Enter the IP address of the Prestige. 192.168.1.1 is the Prestige default IP address when shipped.
Send/Fetch	Press “Send” to upload the file to the Prestige and “Fetch” to back up the file on your computer.
Local File	Enter the path and name of the firmware file (*.bin extension) or configuration file (*.rom extension) on your computer.
Remote File	This is the filename on the Prestige. The filename for the firmware is “ras” and for the configuration file, is “rom-0”.
Binary	Transfer the file in binary mode.
Abort	Stop transfer of the file.

1.2 Upload Router Configuration File

The configuration data, system-related data, the error log and the trace log are all stored in the configuration file. Please be aware that uploading the configuration file replaces all previous configurations. You can upgrade the configuration file either through an FTP or TFTP client program (preferred method) or through the RS-232 console port (in the event of the network being down). Updating the configuration file via the console port under normal conditions is not recommended since FTP or TFTP is faster. Please note that you need to reboot the system after the configuration file update process is complete. Note that if you replace the current configuration with the default configuration file, i.e., prestige.rom, you will lose all configurations that you had before and the speed of the console port will be reset to the default of 9600 bps with 8 data bit, no parity and 1 stop bit(8n1). You will need to change your serial communication software to the default before you can connect to the Prestige again. The password will be reset to the default of 1234, as well.

1.2.1 Upload Router Configuration File using the Console Port

Select 2 from **Menu 24.7 – System Maintenance – Upload Firmware** to go to **Menu 24.7.2 - System Maintenance - Upload Router Configuration File**. Follow the instructions as shown in the following screen.

```
Menu 24.7.2 - System Maintenance - Upload Router Configuration File

To upload router configuration file:
1. Enter "y" at the prompt below to go into debug mode.
2. Enter "atlc" after "Enter Debug Mode" message.
3. Wait for "Starting XMODEM upload" message before activating
   Xmodem upload on your terminal.
4. After successful firmware upload, enter "atgo" to restart the
   router.

Warning:
1. Proceeding with the upload will erase the current
   configuration file.
2. The router's console port speed (Menu 24.2.2) may change
   when it is restarted; please adjust your terminal's speed
   accordingly. The password may change (menu 23), also.
3. When uploading the DEFAULT configuration file, the console
   port speed will be reset to 9600 bps and the password to
   "1234".

Do You Which To Proceed:(Y/N)
```

Figure 10-12 Menu 24.7.2 as seen using the Console Port

Follow the procedure as shown previously for the HyperTerminal program. The procedure for other serial communications programs should be similar.

- Step 1** Click "Transfer" in the HyperTerminal menu bar, then "Send File" from the drop-down menu.
- Step 2** Enter the path and name of the rom configuration file (*.rom extension) on your computer.
- Step 3** Choose the **Xmodem** Protocol.
- Step 4** Finally, press **Send**.
- Step 5** The system reboots automatically after a successful firmware upload.

1.2.2 Upload Router Configuration File using FTP

To upload the router configuration file, follow the instructions as shown in the following screen (Menu 24.7.2 using Telnet). See also the FTP example earlier in this chapter.

Menu 24.7.2 - System Maintenance - Upload Router Configuration File

To upload the router configuration file, follow the procedure below:

1. Launch the FTP client on your workstation.
2. Type "open" and the IP address of your Prestige. Then type "root" and your SMT password as requested.
3. Type "put *configurationfilename* rom-0" where "*configurationfilename*" is the name of your router configuration file on your workstation, which will be transferred to the "rom-0" file on the Prestige.
4. The system reboots automatically after the upload is complete.

For details on FTP commands, please consult the documentation of your FTP client program. For details on uploading router firmware using TFTP (note that you must remain in menu 24.7.2 to upload the router configuration file using TFTP), please see the Prestige manual.

Press ENTER to Exit:

Figure 10-13 Menu 24.7.2 as seen using Telnet

1.2.3 Upload Router Configuration File using TFTP

Even though TFTP should work over WAN as well, it is not recommended.

To use TFTP, your workstation must have both telnet and TFTP clients. To transfer the configuration file, follow the procedure below and example shown earlier in this chapter.

Chapter 11: System Maintenance & Information

This chapter leads you through SMT menus 24.8 to 24.11.

11.1 Command Interpreter Mode

This option allows you to enter command interpreter mode, a “DOS prompt” type command interface, which allows more advanced system diagnosis and troubleshooting (beyond the scope of this guide). See our supporting CD or the zyxel web site at www.zyxel.com for more detailed information on CI commands. Enter **8** from **Menu 24 - System Maintenance**. A list of valid commands can be found by typing [help] or [?] at the command prompt. Type “exit” to return to the SMT main menu when finished.

```
Menu 24 - System Maintenance

1. System Status
2. System Information and Console Port Speed
3. Log and Trace
4. Diagnostic
5. Backup Configuration
6. Restore Configuration
7. Firmware Update
8. Command Interpreter Mode
9. Call Control
10. Time and Date Setting

Enter Menu Selection Number:
```

Figure 11-1 Command Mode

11.2 Call Control Support

The Prestige provides two call control functions: budget management and call history. Please note that this menu is only applicable when **Encapsulation** is set to **PPPoE** in Menu 4 or Menu 11.1.

The budget management function allows you to set a limit on the total outgoing call time of the Prestige within certain times. When the total outgoing call time exceeds the limit, the current call will be dropped and any future outgoing calls will be blocked.

Call history chronicles preceding incoming and outgoing calls.

To access the call control menu, select option **9. Call Control** in **Menu 24** to go to **Menu 24.9 - System Maintenance - Call Control**, as shown in the next table.

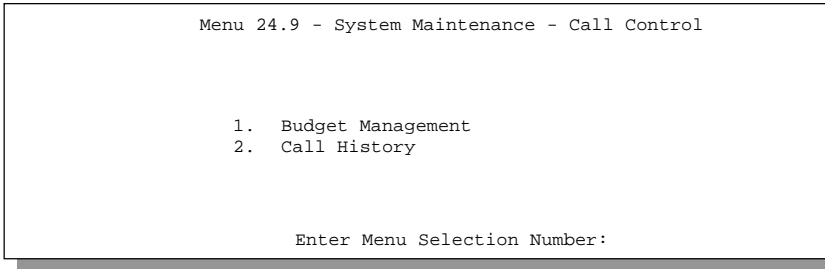

Figure 11-2 Call Control

11.2.1 Budget Management

Menu 24.9.3 shows the budget management statistics for outgoing calls. Enter **1** from **Menu 24.9 - System Maintenance - Call Control** to bring up the following menu.

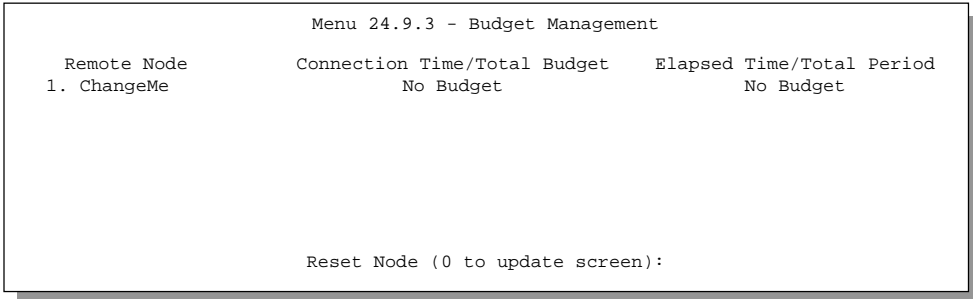

Figure 11-3 Budget Management

The total budget is the time limit on the accumulated time for outgoing calls to a remote node. When this limit is reached, the call will be dropped and further outgoing calls to that remote node will be blocked. After each period, the total budget is reset. The default for the total budget is 0 minutes and the period is 0 hours, meaning no budget control. You can reset the accumulated connection time in this menu by entering the index of a remote node. Enter **1** to clear the budget and **0** to update the screen. The budget and the reset period can be configured in Menu 11.1 (see *Figure 5-3*) for the remote node.

Table 11-1 Budget Management

Field	Description	Example
Remote Node	Enter the index number of the remote node you want to reset (just one in this case)	1
Connection Time/Total Budget	This is the total connection time (within the allocated budget that you set in <i>Figure 5-3</i>) that has gone by.	5/10 means that 5 minutes out of a total allocation of 10 minutes have gone by.
Elapsed Time/Total Period	The period is the time cycle in hours that the allocation budget is reset (see <i>Table 5-3</i>). The elapsed time is the time used up within this period.	0.5/1 means that 30 minutes out of the 1 hour time period has gone by.

11.2.2 Call History

This is the second option in **Menu 24.9 - System Maintenance - Call Control**. It displays information about past incoming and outgoing calls. Enter 2 from **Menu 24.9 - System Maintenance - Call Control** to bring up the following menu.

Menu 24.9.4 - Call History						
Phone Number	Dir	Rate	#call	Max	Min	Total
1.						
2.						
3.						
4.						
5.						
6.						
7.						
8.						
9.						
10.						
Enter Entry to Delete(0 to exit):						

Figure 11-4 Call History

Table 11-2 Call History Fields

Field	Description
Phone Number	The PPPoE service names are shown here.
Dir	This shows whether the call was incoming or outgoing.
Rate	This is the transfer rate of the call.
#call	This is the number of calls made to or received from that telephone number.
Max	This is the length of time of the longest telephone call.
Min	This is the length of time of the shortest telephone call.
Total	This is the total length of time of all the telephone calls to/from that telephone number.

11.3 Time and Date Setting

There is no Real Time Chip (RTC) chip in the Prestige, so we have a software mechanism to get the current time and date from an external server when you power up your Prestige. **Menu 24.10** does just that – it allows you to update the time and date settings of your Prestige. The real time is then displayed in the Prestige error logs. If you do not choose a time service protocol that your timeserver will send when the Prestige powers up you can enter the time manually but each time the system is booted, the time & date will be reset to **2000/01/01 0:0:0**.

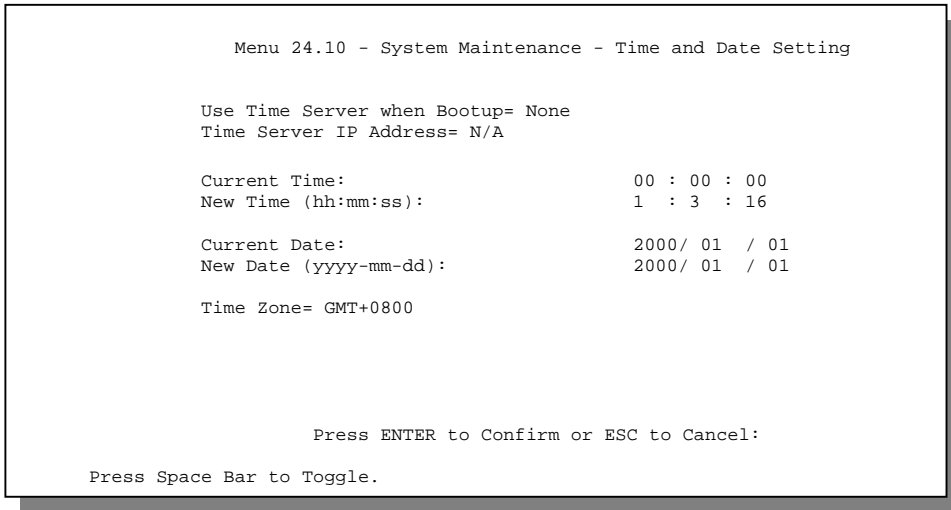

Figure 11-5 System Maintenance – Time and Date Setting

Table 11-3 Time and Date Setting Fields

Field	Description
Use Time Server when Bootup=	Enter the time service protocol that your timeserver will send when the Prestige powers up. Choices are Daytime (RFC 867) , Time (RFC-868) , NTP (RFC-1305) and None . The main differences between them are the format, e.g., the Daytime (RFC 867) format is day/month/date/year/time zone of the server while the Time (RFC-868) format gives a 4-byte integer giving the total number of seconds since 1/1/1970 at 0:0:0. The NTP (RFC-1305) format is similar. Not all timeservers support all protocols, so you may have to check with your ISP/network administrator or use trial and error to find a protocol that works. If you select None (this is the default value), you can enter the time manually but each time the system is booted, the time & date will be reset to 2000/01/01 0:0:0 .
Time Server IP Address=	Enter the IP address of the your timeserver. Check with your ISP/network administrator if you are unsure of this information.
Current Time: New Time	Enter the new time in hour, minute and second format.
Current Date: New Date	Enter the new date in year, month, date format.
Time Zone= GMT+0800	Press the [SPACE BAR] to set the time difference between your time zone and Greenwich mean Time (GMT). Be aware if/when daylight

	savings time alters this time difference for your time zone.
--	--

Once you have filled in the new time and date, press [Enter] to save the setting and press [Esc] to return to Menu 24 .
--

11.4 Boot commands

In Debug mode, enter ATHE to view Prestige boot module commands as shown below and then enter ATGO to continue booting the system. For ATBAX, x denotes the number preceding the colon to give the baud rate following the colon in the list of numbers that follows; e.g., ATBA3 will give a baud of 9.6 Kbps. ATSE displays the seed that is used to generate a password to turn on the debug flag in the firmware. The ATSH command shows product related information such as boot module version, vendor name, product model, RAS code revision, etc.

```

===== Debug Command Listing =====
AT          just answer OK
ATHE       print help
ATBAX      change baudrate. 1:38.4k, 2:19.2k, 3:9.6k 4:57.6k
5:115.2k
ATENx,(y)  set BootExtension Debug Flag (y=password)
ATSE       show the seed of password generator
ATTI(h,m,s) change system time to hour:min:sec or show current time
ATDA(y,m,d) change system date to year/month/day or show current date
ATDS       dump RAS stack
ATDT       dump Boot Module Common Area
ATDUx,y    dump memory contents from address x for length y
ATWBx,y    write address x with 8-bit value y
ATWWx,y    write address x with 16-bit value y
ATWLx,y    write address x with 32-bit value y
ATRBx      display the 8-bit value of address x
ATRwx      display the 16-bit value of address x
ATRLx      display the 32-bit value of address x
ATGO(x)    run program at addr x or boot router
ATGR       boot router
ATGT       run Hardware Test Program
AT%Tx      Enable Hardware Test Program at boot up
<press any key to continue>

```

Figure 11-6 Boot Module Commands

Chapter 12: Call Schedule Setup

The call scheduling feature allows the Prestige to manage a remote node and dictate when a remote node should be called and for how long. This feature is just like the scheduler in a video recorder (record the program you want in a specified time). You can apply up to 4 schedule sets in **Menu 11.1 - Remote Node Profile**. You configure each schedule in **Menu 26 - Schedule Setup**. Enter 26 from the main menu to bring up the following screen.

```

Menu 26 - Schedule Setup

Schedule          Schedule
Set #            Name          Set #            Name
-----          -
1                _____  7                _____
2                _____  8                _____
3                _____  9                _____
4                _____  10               _____
5                _____  11               _____
6                _____  12               _____

Enter Schedule Set Number to Configure=
Edit Name=
Press ENTER to CONFIRM or ESC to CANCEL:

```

Figure 12-1 Schedule Setup

As we can have multiple sets that are applied in turn, lowered numbered sets take precedence over higher numbered sets in case of conflict. For example, if we apply sets 1,2,3,4 in a remote node, then set 1 will take precedence over set 2, 3 and 4 as it is applied first. Set 2 will take precedence over set 3 and 4, and so on. You can design up to 12 schedule sets but you can only apply up to 4 schedule sets for a remote node.

To delete a schedule set, enter the set number and press the [Space Bar] (or delete) in the Edit Name field to delete the set name.

To setup a schedule set select the schedule set you want to setup from **Menu 26** (no. 1-12) and press [Enter] to see **Menu 26.1 - Schedule Set Setup** as shown next.

```
Menu 26.1 - Schedule Set Setup

Active= Yes
Start Date (mm/dd/yyyy) = 1990-1-1
How Often= Once
Once:
  Date (mm/dd/yyyy) = 1990-1-2
Weekdays:
  Sunday= N/A
  Monday= N/A
  Tuesday= N/A
  Wednesday= N/A
  Thursday= N/A
  Friday= N/A
  Saturday= N/A
Start Time (hh : mm) = 10 : 20
Duration (hh : mm) = 01 :00
Action= Forced On
Press ENTER to Confirm or ESC to Cancel:
```

Figure 12-2 Schedule Set Setup

The action for a remote node configured with a schedule set is **Forced On**, **Forced Down**, **Enable Dial-On-Demand**, or **Disable Dial-On-Demand**. **Forced On** means that the connection is maintained whether or not there is a demand call on the line and persist for the time period specified in the **Duration** field. **Forced Down** means that the connection is blocked whether or not there is a demand call on the line. **Enable Dial-On-Demand** means that this schedule permits a demand call on the line. **Disable Dial-On-Demand** means that this schedule prevents a demand call on the line. If a connection has been already established, it will not drop it. Once the connection is dropped manually or it times out, then that remote node can't be triggered up until the end of the **Duration**.

Table 12-1 Schedule Set Setup Fields

Field	Description	Option
Active	Press the [Space Bar] to toggle between Yes and No. Choose Yes and press [Enter] to activate the set.	Yes No
Start Date	Enter the start date that you wish the set to take effect in year-month-date format. Valid dates are from January 1, 1990 to February 5, 2036.	
How Often	Should this schedule set recur weekly or be used just once only? Press the [Space Bar] to toggle between Once and Weekly. Both these options are mutually exclusive. If Once is selected, then all weekday settings are N/A. When Once is selected, the schedule rule deletes automatically after the scheduled time elapses.	Once Weekly
Once: Date	If you selected Once in the How Often field above, then enter the date the set should activate here in year-month-date format.	
Weekday: Day	If you selected Weekly in the How Often field above, then select the day(s) the set should activate (and recur) by going to that day(s) and pressing the [Space Bar], then [Enter] to select Yes.	Yes No N/A
Start Time	Enter the start time that you wish the set to take effect in hour : minute format.	
Duration	Enter the maximum duration allowed in hour : minute format for this scheduled connection per call.	
Action	Press the [Space Bar] to toggle between these options. Choose one and then press [Enter].	Forced On, Forced Down, Enable Dial-On-Demand, or Disable Dial-On-Demand.

12.1.1 Applying A Schedule Set

After you've configured your schedule sets, you must apply them to the desired remote node(s). Enter **11** from the **Main Menu** and then select either **PPPoE** or **PPTP** encapsulation. You can apply up to 4 schedule sets, separated by commas, for one remote node.

```
Menu 11.1 - Remote Node Profile

Rem Node Name= ChangeMe          Route= IP
Active= Yes

Encapsulation= PPTP              Edit IP= No
Service Type= Standard           Telco Option:
Service Name=N/A                 Allocated Budget(min)= 0
Outgoing=                         Period(hr)= 0
  My Login=                       Schedules= 1,2,3,4
  My Password= *****           Nailed-up Connections=

PPTP :                            Session Options:
IP Addr=                          Edit Filter Sets= No
Server IP Addr=                    Idle Timeout(sec)= 100
Connection ID/Name=

Press ENTER to Confirm or ESC to Cancel:

Press Space Bar to Toggle.
```

Figure 12-3 Applying Schedule Set(s) to A Remote Node

Chapter 13: Telnet Configuration and Capabilities

This chapter covers the Telnet Configuration and Capabilities of the Prestige.

13.1 About Telnet Configuration

Before the Prestige is properly setup for TCP/IP, the only option for configuring it is through the console port. Once your Prestige is configured, you can use telnet to configure it remotely as shown below.

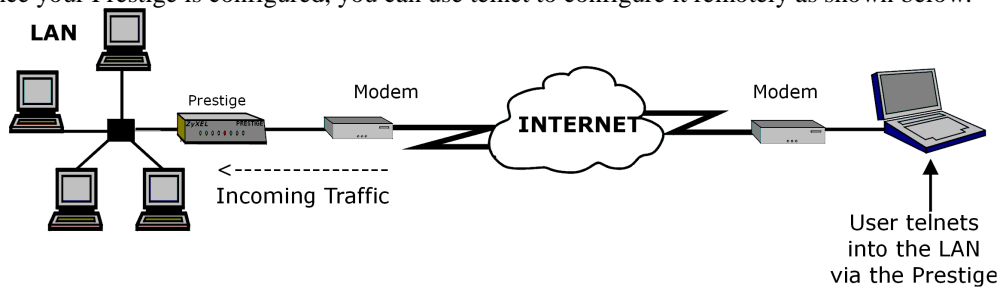

Figure 13-1 Telnet Configuration on a TCP/IP Network

When IP routing is disabled, the Prestige can still function as a host.

13.2 Telnet Under SUA

When SUA is enabled and an inside server is specified, telnet connections from the outside will be forwarded to the inside server. So to configure the Prestige via telnet from the outside, you must first telnet to the inside server, and then telnet from the server to the Prestige using its inside LAN IP address. If no insider server is specified, telnet to the SUA's IP address will connect to the Prestige directly.

13.3 Telnet Capabilities

13.3.1 Single Administrator

To prevent confusion and discrepancy on the configuration, your Prestige only allows one administrator to log in at any time. Your Prestige also gives priority to the console port over telnet. If you have already connected to your Prestige via telnet, you will be logged out if another user logs in to the Prestige via the console port.

13.3.2 System Timeout

There is a system timeout of 5 minutes (300 seconds) for either the console port or telnet. Your Prestige will automatically log you out if you do nothing in this timeout period, except when it is continuously updating the status in **Menu 24.1**.

Part IV:

Troubleshooting

Chapter 18 provides information about solving common problems, some Appendices, as well as a Glossary and Index.

Chapter 14: Troubleshooting

This chapter covers the potential problems you may run into and the possible remedies. After each problem description, some instructions are provided to help you to diagnose and to solve the problem. Please see our supporting CD for further information.

14.1 Problems Starting Up the Prestige

Table 14-1 Troubleshooting the Start-Up of your Prestige

Problem	Corrective Action	
None of the LEDs are on when you power on the Prestige	Check the connection between the AC adapter and the Prestige. If the error persists, you may have a hardware problem. In this case, you should contact technical support.	
Cannot access the Prestige via the console port.	1. Check to see if the Prestige is connected to your computer's serial port.	
	2. Check to see if the communications program is configured correctly. The communications software should be configured as follows:	VT100 terminal emulation
		9600 bps No parity, 8 Data bits, 1 Stop bit, Data Flow set to None.

14.2 Problems with the LAN Interface

Table 14-2 Troubleshooting the LAN Interface

Problem	Corrective Action
Can't ping any workstation on the LAN	Check the 10M/100M LEDs on the front panel. One of these LEDs should be on. If they are both off, check the cables between your Prestige and hub or the station.
	Verify that the IP address and the subnet mask are consistent between the Prestige and the workstations.

14.3 Problems with the WAN interface

Table 14-3 Troubleshooting the WAN interface

Problem	Corrective Action
Cannot get WAN IP from the ISP	<p>The WAN IP is provided when the ISP recognizes the user as an authorized user after verifying the MAC address or Host Name or User ID.</p> <p>Find out the verification method used by your ISP.</p>
	<p>If the ISP checks the LAN MAC Address, tell the ISP the WAN MAC address of the Prestige. The WAN MAC can be obtained from Menu 24.1.</p> <p>In case the ISP does not allow you to use a new MAC, you can clone the MAC from the LAN as the WAN MAC and send it to the ISP using Menu 2 - WAN Setup.</p>
	<p>If the ISP checks the Host Name, enter host name in the system field in Menu 1 - General Setup when you connect the Prestige to a cable/xDSL modem.</p>
	<p>If the ISP checks the User ID, make sure that you have entered the correct Service Type, User Name and Password in Menu 4 - Internet Access Setup.</p>
Can't connect to a remote node or ISP	Check Menu 24.1 to verify the line status. If it indicates Down, then refer to the section on the line problems.

14.4 Problem with Remote Node or ISP Connection

Table 14-4 Remote Node or ISP Connection

Problem	Corrective Action
Cannot connect to a remote node or ISP	Check Menu 24.1 to verify the line status. If it indicates [down], then refer to the section on the line problems.
	In Menu 11.1, verify your login name and password for the remote node.

14.5 Problems with Internet Access

Table 14-5 Internet Access

Problem	Corrective Action
Cannot access the Internet.	Connect your Cable/xDSL modem with the Prestige using appropriate cable.
	Check with the manufacturer of your Cable/xDSL modem about the cable requirement because for some modems you may require crossover cable and for others regular patch cable.
	Verify your settings in Menu 3.2 and Menu 4.

14.6 General Instructions

If you have other problems you can try the following options.

- Check the **Menu 24.1 System Maintenance – Status**, **Menu 24.2.1 - System Information** and **Menu 24.3 System Maintenance –Log and Trace** in order to locate the problem.
- Check the Troubleshooting section in the Support Notes.
- Use Debug commands to diagnose problems. In general, ZyXEL recommends that you use these commands with the direction of your customer support representative.

Appendix A: PPTP

What is PPTP?

PPTP (Point-to-Point Tunneling Protocol) is a Microsoft proprietary protocol (RFC 2637 for PPTP is informational only) to tunnel PPP frames.

How can we transport PPP frames from a PC to a broadband modem over Ethernet?

A solution is to build PPTP into the ANT (ADSL Network Termination) where PPTP is used only over the short haul between the PC and the modem over Ethernet. For the rest of the connection, the PPP frames are transported with PPP over AAL5 (RFC 2364). The PPP connection, however, is still between the PC and the ISP. The various connections in this setup are depicted in the following diagram. The drawback of this solution is that it requires one separate ATM VC per destination.

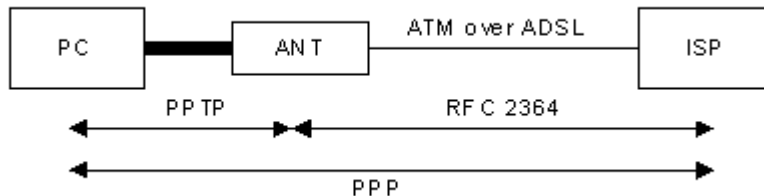

PPTP and the Prestige

When the Prestige is deployed in such a setup, it appears as a PC to the ANT (ADSL Network Termination). In Windows VPN or PPTP Pass-Through feature, the PPTP tunneling is created from Windows 95, 98 and NT clients to an NT server in a remote location. The pass-through feature allows users on the network to access a different remote server using the Prestige's Internet connection. In SUA mode, the Prestige is able to pass the PPTP packets to the internal PPTP server (i.e. NT server) behind the NAT. Users need to forward PPTP packets to port 1723 by configuring the server in **Menu 15.1**. In the case above as the PPTP connection is initialized by the remote PPTP Client, the user must configure the PPTP clients. For the Prestige the PPTP connection is initialized by the Prestige and hence, there is no need to configure the remote PPTP clients.

PPTP Protocol Overview

PPTP is very similar to L2TP, since L2TP is based on both PPTP and L2F (Cisco's Layer 2 Forwarding). Conceptually, there are three parties in PPTP, namely the PNS (PPTP Network Server), the PAC (PPTP Access Concentrator) and the PPTP user. The PNS is the box that hosts both the PPP and the PPTP stacks and forms one end of the PPTP tunnel. The PAC is the box that dials/answers the phone calls and relays the PPP frames to the PNS. The PPTP user is not necessarily a PPP client (can be a PPP server too). Both the PNS and the PAC must have IP connectivity; however, the PAC must in addition have dial-up capability. The phone call is between the user and the PAC and the PAC tunnels the PPP frames to the PNS. The PPTP user is unaware of the tunnel between the PAC and the PNS.

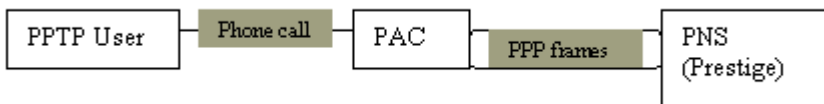

Microsoft includes PPTP as a part of the Windows OS. In Microsoft's implementation, the PC, and hence the Prestige, is the PNS that requests the PAC (the ANT) to place an outgoing call over AAL5 to an RFC 2364 server.

Control & PPP connections

Each PPTP session has distinct control connection and PPP data connection.

Call Connection

The control connection runs over TCP. Similar to L2TP, a tunnel control connection is first established before call control messages can be exchanged. Please note that a tunnel control connection supports multiple call sessions.

The following diagram depicts the message exchange of a successful call setup between a PC and an ANT.

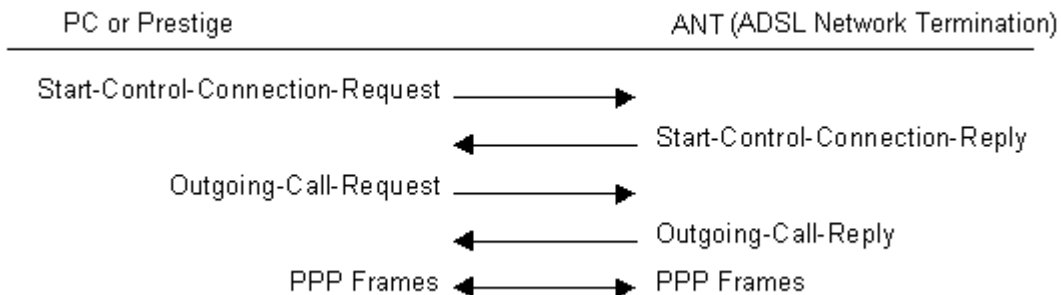

PPP Data Connection

The PPP frames are tunneled between the PNS and PAC over GRE (General Routing Encapsulation, RFC 1701, 1702). The individual calls within a tunnel are distinguished using the Call ID field in the GRE header.

Appendix B: PPPoE

PPPoE in Action

An ADSL modem bridges a PPP session over Ethernet (PPP over Ethernet, RFC 2516) from your PC to an ATM PVC (Permanent Virtual Circuit) which connects to a xDSL Access Concentrator where the PPP session terminates (see the next figure). One PVC can support any number of PPP sessions from your LAN. PPPoE provides access control and billing functionality in a manner similar to dial-up services using PPP.

Benefits of PPPoE

PPPoE offers the following benefits:

1. It provides you with a familiar dial-up networking (DUN) user interface.
2. It lessens the burden on the carriers of provisioning virtual circuits all the way to the ISP on multiple switches for thousands of users. For GSTN (PSTN & ISDN), the switching fabric is already in place.
3. It allows the ISP to use the existing dial-up model to authenticate and (optionally) to provide differentiated services.

Traditional Dial-up Scenario

The following diagram depicts a typical hardware configuration where the PCs use traditional dial-up networking.

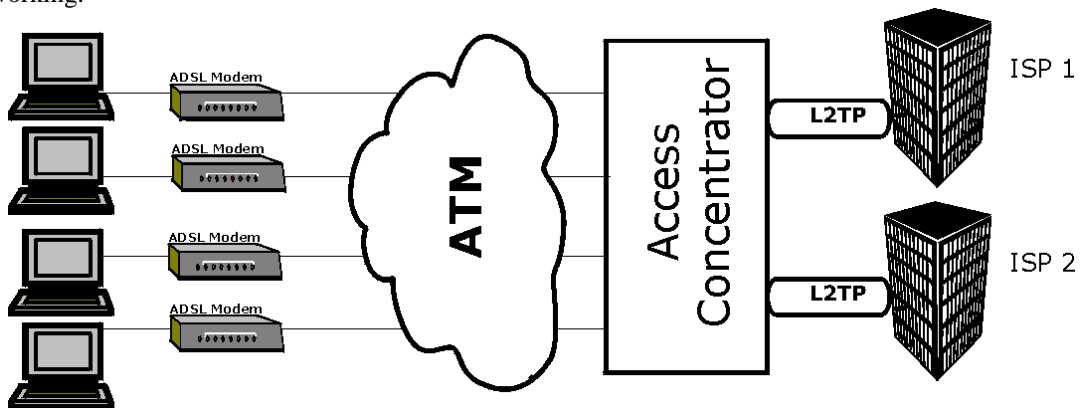

Diagram 1 Single-PC per Modem Hardware Configuration

How PPPoE Works

The PPPoE driver makes the Ethernet appear as a serial link to the PC and the PC runs PPP over it, while the modem bridges the Ethernet frames to the Access Concentrator (AC). Between the AC and an ISP, the AC is acting as a L2TP (Layer 2 Tunneling Protocol) LAC (L2TP Access Concentrator) and tunnels the PPP frames to the ISP. The L2TP tunnel is capable of carrying multiple PPP sessions.

With PPPoE, the VC (Virtual Circuit) is equivalent to the dial-up connection and is between the modem and the AC, as opposed to all the way to the ISP. However, the PPP negotiation is between the PC and the ISP.

Prestige as a PPPoE Client

When using the Prestige as a PPPoE client, the PCs on the LAN see only Ethernet and are not aware of PPPoE. This alleviates the administrator from having to manage the PPPoE clients on the individual PCs.

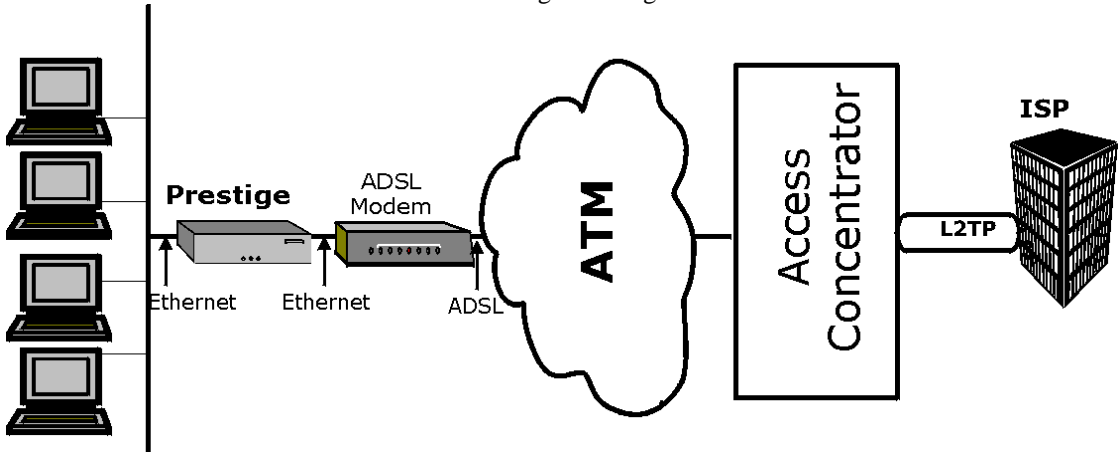
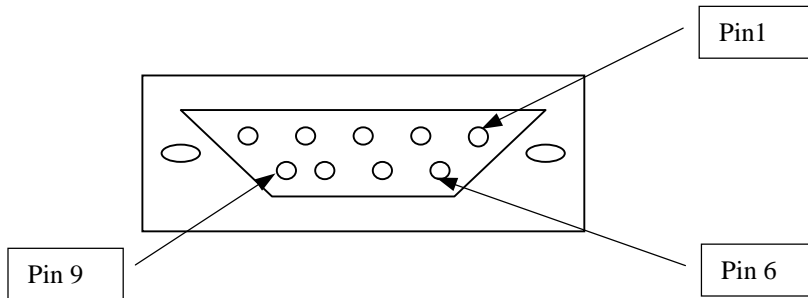

Diagram 2 **Prestige as a PPPoE Client**

Appendix C: Hardware Specifications

Power Specification	I/P AC 120V / 60Hz ; O/P DC 12V 1200 mA
MTBF	100000 hrs
Operation Temperature	0° C ~ 40° C
Ethernet Specification for WAN	10Mbit Half / Full Manual Setting
Ethernet Specification for LAN	10/100 Mbit Half / Full Auto-negotiation
Console Port RS – 232	Pin 1 = NON ; Pin 2 = DTE-RXD; Pin 3 = DTE-TXD; Pin 4 = DTE-DTR; Pin 5 = GND; Pin 6 = DTE-DSR; Pin 7 = DTE-RTS; Pin 8 = DTE-CTS; PIN 9 = NON. See Figure below



WAN/LAN Cable Pin Layout:			
Straight-Through		Crossover	
(Switch)	(Adapter)	(Switch)	(Switch)
1 IRD +	1 OTD +	1 IRD +	1 IRD +
2 IRD -	2 OTD -	2 IRD -	2 IRD -
3 OTD +	3 IRD +	3 OTD +	3 OTD +
6 OTD -	6 IRD -	6 OTD -	6 OTD -

Appendix D: Important Safety Instructions

The following safety instructions apply to the Prestige:

1. Be sure to read and follow all warning notices and instructions.
2. The maximum recommended ambient temperature for the Prestige is 40°(104°). Care must be taken to allow sufficient air circulation or space between units when the Prestige is installed inside a closed rack assembly. The operating ambient temperature of the rack environment might be greater than room temperature.
3. Installation in a rack without sufficient airflow can be unsafe.
4. Racks should safely support the combined weight of all equipment.
5. The connections and equipment that supply power to the Prestige should be capable of operating safely with the maximum power requirements of the Prestige. In case of a power overload, the supply circuits and supply wiring should not become hazardous. The input rating of the Prestige is printed on the nameplate.
6. The AC adapter must plug in to the right supply voltage, i.e. 120VAC adapter for North America and 230VAC adapter for Europe. Make sure that the supplied AC voltage is correct and stable. If the input AC voltage is over 10% lower than the standard may cause the Prestige to malfunction.
7. Installation in restricted access areas must comply with Articles 110-16, 110-17, and 110-18 of the National Electrical Code, ANSI/NFPA 70.
8. Do not allow anything to rest on the power cord of the AC adapter, and do not locate the product where anyone can walk on the power cord.
9. Do not service the product by yourself. Opening or removing covers can expose you to dangerous high voltage points or other risks. Refer all servicing to qualified service personnel.
10. Generally, when installed after the final configuration, the product must comply with the applicable safety standards and regulatory requirements of the country in which it is installed. If necessary, consult the appropriate regulatory agencies and inspection authorities to ensure compliance.
11. A rare condition can create a voltage potential between the earth grounds of two or more buildings. If products installed in separate building are interconnected, the voltage potential can cause a hazardous condition. Consult a qualified electrical consultant to determine whether or not this phenomenon exists and, if necessary, implement corrective action before interconnecting the products. If the equipment is to be used with telecommunications circuit, take the following precautions:
 - Never install telephone wiring during a lightning storm.
 - Never install telephone jacks in wet location unless the jack is specially designed for wet location.
 - Never touch uninsulated telephone wires or terminals unless the telephone line has been disconnected at the network interface.
 - Use caution when installing or modifying telephone lines (other than a cordless telephone) during an electrical storm. There is a remote risk of electric shock from lightning.
 - Do not use a telephone or other equipment connected to telephone lines to report a gas leak near the leak.

Glossary of Terms

Bandwidth	This is the capacity on a link usually measured in bits-per-second (bps).
Bit	(Binary Digit) -- A single digit number in base-2, in other words, either a 1 or a zero. The smallest unit of computerized data.
Broadband	Broadband refers to telecommunication that provides multiple channels of data over a single communications medium.
Byte	A set of bits that represent a single character. There are 8 bits in a Byte.
CDR	Call Detail Record. This is a name used by telephone companies for call related information.
CHAP	Challenge Handshake Authentication Protocol is an alternative protocol to PAP. It avoids sending passwords over the wire by using a challenge/response technique.
Client	A software program that is used to contact and obtain data from a Server software program on another computer. Each Client program is designed to work with one or more specific kinds of Server programs, and each Server requires a specific kind of Client. A Web Browser is a specific kind of Client.
Crossover Ethernet cable	A cable that wires a pin to its opposite pin, for example, RX+ is wired to TX+. This cable connects two similar devices, for example, two data terminal equipment (DTE) or data communications equipment (DCE) devices.
DHCP	Dynamic Host Configuration Protocol automatically assigns IP addresses to clients when they log on. DHCP centralizes IP address management on central computers that run the DHCP server program. DHCP leases addresses for a period of time which means that addresses are made available to assign to other systems.
DNS	Domain Name System. A database of domain names and their IP addresses. DNS is the primary naming system for many distributed networks, including the Internet.
Domain Name	The unique name that identifies an Internet site. Domain Names always have 2 or more parts, separated by dots. The part on the left is the most specific, and the part on the right is the most general.
DSL/xDSL	Digital Subscriber Line technologies enhances the data capacity of the existing twisted-pair wire that runs between the local telephone company switching offices and most homes and offices. There are actually seven types of DSL service, ranging in speeds from 16 Kbits/sec to 52 Mbits/sec. The services are either symmetrical (traffic flows at the same speed in both directions), or asymmetrical (the downstream capacity is higher than the upstream capacity). DSL connections are point-to-point dedicated circuits, meaning that they are always connected. There is no dial-up. There is also no switching, which means that the line is a direct connection into the carrier's frame

	relay, ATM (Asynchronous Transfer Mode), or Internet-connect system.
DSLAM	A Digital Subscriber Line Access Multiplexer (DSLAM) is a network device, usually at a telephone company central office, that receives signals from multiple customer Digital Subscriber Line connections and puts the signals on a high-speed backbone line using multiplexing techniques. Depending on the product, DSLAM multiplexers connect DSL lines with some combination of asynchronous transfer mode ATM, frame relay, or IP networks.
Ethernet	A very common method of networking computers in a LAN. There are a number of adaptations to the IEEE 802.3 Ethernet standard, including adaptations with data rates of 10 Mbits/sec and 100 Mbits/sec over coaxial cable, twisted-pair cable, and fiber-optic cable. The latest version of Ethernet, Gigabit Ethernet, has a data rate of 1 Gbit/sec.
Flash memory	The nonvolatile storage that can be electrically erased and reprogrammed so that data can be stored, booted, and rewritten as necessary.
FTP	File Transfer Protocol is an Internet file transfer service that operates on the Internet and over TCP/IP networks. FTP is basically a client/server protocol in which a system running the FTP server accepts commands from a system running an FTP client. The service allows users to send commands to the server for uploading and downloading files. FTP is popular on the Internet because it allows for speedy transfer of large files between two systems.
Gateway	A gateway is a computer system or other device that acts as a translator between two systems that do not use the same communication protocols, data formatting structures, languages, and/or architecture.
Host	Any computer on a network that is a repository for services available to other computers on the network. It is quite common to have one host machine provide several services, such as WWW and USENET.
HTTP	Hyper Text Transfer Protocol. The most common protocol used on the Internet. HTTP is the primary protocol used for web sites and web browsers. It is also prone to certain kinds of attacks.
IANA	Internet Assigned Number Authority acts as the clearinghouse to assign and coordinate the use of numerous Internet protocol parameters such as Internet addresses, domain names, protocol numbers, and more. The IANA Web site is at http://www.isi.edu/iana .
ICMP	Internet Control Message Protocol is a message control and error-reporting protocol between a host server and a gateway to the Internet. ICMP uses Internet Protocol (IP) datagrams, but the messages are processed by the TCP/IP software and are not directly apparent to the application user.
Intranet	A private network inside a company or organization that uses the same kinds of

	software that you would find on the public Internet, but that is only for internal use.
IP	Internet Protocol The IP (currently IP version 4, or IPv4), is the underlying protocol for routing packets on the Internet and other TCP/IP-based networks.
IPCP (PPP)	IP Control Protocol allows changes to IP parameters such as the IP address.
IPX	Internetwork Packet eXchange The native NetWare internetworking protocol is IPX (Internetwork Packet Exchange). Like IP (Internet Protocol), IPX is an internetworking protocol that provides datagram services.
ISP	Internet Service Providers provide connections into the Internet for home users and businesses. There are local, regional, national, and global ISPs. You can think of local ISPs as the gatekeepers into the Internet.
LAN	Local Area Network is a shared communication system to which many computers are attached. A LAN, as its name implies, is limited to a local area. This has to do more with the electrical characteristics of the medium than the fact that many early LANs were designed for departments, although the latter accurately describes a LAN as well. LANs have different topologies, the most common being the linear bus and the star configuration.
MAC	On a local area network (LAN) or other network, the MAC (Media Access Control) address is your computer's unique hardware number. (On an Ethernet LAN, it's the same as your Ethernet address.) The MAC layer frames data for transmission over the network, then passes the frame to the physical layer interface where it is transmitted as a stream of bits.
NAT	Network Address Translation is the translation of an Internet Protocol address used within one network to a different IP address known within another network - see also SUA.
NDIS	Network Driver Interface Specification is a Windows specification for how communication protocol programs (such as TCP/IP) and network device drivers should communicate with each other.
NetBIOS	Network Basic Input / Output System. NetBIOS is an extension of the DOS BIOS that enables a PC to connect to and communicate with a LAN.
Network	Any time you connect 2 or more computers together so that they can share resources, you have a computer network. Connect 2 or more networks together and you have an internet.
NIC	Network Interface Card. A board that provides network communication capabilities to and from a computer system. Also called an adapter.
Node	Any single computer connected to a network

Packet Filter	A filter that scans packets and decides whether to let them through.
PAP	Password Authentication Protocol PAP is a security protocol that requires users to enter a password before accessing a secure system. The user's name and password are sent over the wire to a server, where they are compared with a database of user account names and passwords. This technique is vulnerable to wiretapping (eavesdropping) because the password can be captured and used by someone to log onto the system.
POP	Post Office Protocol. This is a common protocol used for sending, receiving, and delivering mail messages.
POTS	Plain Old Telephone Service is the analog telephone service that runs over copper twisted-pair wires and is based on the original Bell telephone system. Twisted-pair wires connect homes and businesses to a neighborhood central office. This is called the local loop. The central office is connected to other central offices and long-distance facilities.
PPP	Point to Point Protocol. PPP encapsulates and transmits IP (Internet Protocol) datagrams over serial point-to-point links. PPP works with other protocols such as IPX (Internetwork Packet Exchange). The protocol is defined in IETF (Internet Engineering Task Force) RFC 1661 through 1663. PPP provides router-to-router, host-to-router, and host-to-host connections.
Protocol	A "language" for communicating on a network. Protocols are sets of standards or rules used to define, format, and transmit data across a network. There are many different protocols used on networks. For example, most web pages are transmitted using the HTTP protocol.
Proxy Server	A server that performs network operations in lieu of other systems on the network. Proxy Servers are most often used as part of a firewall to mask the identity of users inside a corporate network yet still provide access to the Internet. When a user connects to a proxy server, via a web browser or other networked application, he submits commands to the proxy server. The server then submits those same commands to the Internet, yet without revealing any information about the system that originally requested the information. Proxy servers are an ideal way to also have all users on a corporate network channel through one point for all external communications. Proxy servers can be configured to block certain kinds of connections and stop some hacks.
PSTN	Public Switched Telephone Network was put into place many years ago as a voice telephone call-switching system. The system transmits voice calls as analog signals across copper twisted cables from homes and businesses to neighborhood COs (central offices); this is often called the local loop. The PSTN is a circuit-switched system, meaning that an end-to-end private circuit is established between caller and callee.

PVC	Permanent Virtual Circuit. A PVC is a logical point-to-point circuit between customer sites. PVCs are low-delay circuits because routing decisions do not need to be made along the way. Permanent means that the circuit is preprogrammed by the carrier as a path through the network. It does not need to be set up or torn down for each session.
RFC	An RFC (Request for Comments) is an Internet formal document or standard that is the result of committee drafting and subsequent review by interested parties. Some RFCs are informational in nature. Of those that are intended to become Internet standards, the final version of the RFC becomes the standard and no further comments or changes are permitted. Change can occur, however, through subsequent RFCs.
RIP	Routing Information Protocol is an interior or intra-domain routing protocol that uses the distance-vector routing algorithms. RIP is used on the Internet and is common in the NetWare environment as a method for exchanging routing information between routers.
Router	A device that connects two networks together. Routers monitor, direct, and filter information that passes between these networks. Because of their location, routers are a good place to install traffic or mail filters. Routers are also prone to attacks because they contain a great deal of information about a network.
Server	A computer, or a software package, that provides a specific kind of service to client software running on other computers.
SNMP	System Network Management Protocol is a popular management protocol defined by the Internet community for TCP/IP networks. It is a communication protocol for collecting information from devices on the network.
STP	Twisted-pair cable consists of copper-core wires surrounded by an insulator. Two wires are twisted together to form a pair, and the pair form a balanced circuit. The twisting prevents interference problems. STP (shielded twisted-pair) provides protection against external crosstalk.
Straight through Ethernet cable	A cable that wires a pin to its equivalent pin. This cable connects two dissimilar devices, for example, a data terminal equipment (DTE) device and a data communications equipment (DCE) device. A straight through Ethernet cable is the most common cable used.
SUA	Single User Account – The Prestige's SUA (Single User Account) feature allows multiple user Internet access for the cost of a single ISP account - see also NAT.
TCP	Transmission Control Protocol handles flow control and packet recovery and IP providing basic addressing and packet-forwarding services.
Telnet	Telnet is the login and terminal emulation protocol common on the Internet and in UNIX environments. It operates over TCP/IP networks. Its primary function is to allow users to log into remote host systems.

Terminal	A device that allows you to send commands to a computer somewhere else. At a minimum, this usually means a keyboard and a display screen and some simple circuitry.
Terminal Emulation Software	Software that pretends to be (emulates) a physical terminal and allows you to type commands to a computer somewhere else.
TFTP	Trivial File Transfer Protocol is an Internet file transfer protocol similar to FTP (File Transfer Protocol), but it is scaled back in functionality so that it requires fewer resources to run. TFTP uses the UDP (User Datagram Protocol) rather than TCP (Transmission Control Protocol).
UDP	UDP is a connectionless transport service that dispenses with the reliability services provided by TCP. UDP gives applications a direct interface with IP and the ability to address a particular application process running on a host via a port number without setting up a connection session.
UNIX	A widely used operating system in large networks.
URL	(Uniform Resource Locator) URL is an object on the Internet or an intranet that resides on a host system. Objects include directories and an assortment of file types, including text files, graphics, video, and audio. A URL is the address of an object that is normally typed in the Address field of a Web browser. The URL is basically a pointer to the location of an object.
VPN	Virtual Private Network. These networks use public connections (such as the Internet) to transfer information. That information is usually encrypted for security purposes.
WAN	Wide Area Network s link geographically dispersed offices in other cities or around the globe. Just about any long-distance communication medium can serve as a WAN link, including switched and permanent telephone circuits, terrestrial radio systems, and satellite systems.
WWW	(World Wide Web) -- Frequently used when referring to "The Internet", WWW has two major meanings - First, loosely used: the whole constellation of resources that can be accessed using Gopher, FTP, HTTP, telnet, USENET, WAIS and some other tools. Second, the universe of hypertext servers (HTTP servers).

Index

A

AT command, 10-1

B

backup, 10-2

Boot commands, 11-6

Broadband Sharing Gateway, xxiii, 1-1

Budget Management, 11-2, 11-3

C

Cable Modem, 2-2, 2-3

Call Control, 11-1

Call History, 11-3, 11-4

Call-Trigerring Packet, 9-10

CDR, 9-7

CHAP, 5-2

Command Interpreter Mode, 11-1

Community, 8-2

console port, 2-3

Console Port, 2-2, 9-4, 9-5, I

Customer Support, ix

D

DDNS

 Configuration, 2-9

DHCP, 1-2, 3-3, 9-11

DHCP (Dynamic Host Configuration Protocol), 1-2, 3-3

Diagnostic, 9-11

DNS, 3-3, 3-6

Domain Name, 3-3, 9-3, 9-5, L

Dynamic DNS, 2-8, 2-9

DYNDNS Wildcard, 2-8

E

Encapsulation

 PPP over Ethernet, G

Error Log, 9-5

Ethernet Encapsulation, 3-8, 5-1, 5-2, 5-3, 5-6, 5-11

F

Factory Default, 2-11

Filename Conventions, 10-1

Filter, 2-12, 5-10, 7-1

 About, 7-1

 Applying, 7-18

 Configuring, 7-4

 Example, 7-14

 Filter log, 9-7

 Generic Filter Rule, 7-12

 Structure, 7-2

 SUA, 7-17

Filters

 Executing a Filter Rule, 7-2

 Logic Flow of an IP Filter, 7-10

Flow Control, 2-4

Front Panel LEDs, 2-1

G

General Setup, 2-8

Glossary, L

H

Hidden Menus, 2-5

HTTP, M, O, Q

HyperTerminal, 10-3

I

IANA, 3-1, 3-2

idle timeout, 5-4
IGMP (Internet Group Multicast Protocol), 3-4
Initial Screen, 2-4
Installation Requirements, 2-3
Internet access, 3-1
Internet Access Setup, 2-6, 3-8, 3-10, 14-2
Internet Assigned Numbers Authority. *See* IANA
Internet Test Setup, 3-13
IP address, 3-1, 3-6
IP Address, 4-1
IP Address Assignment, 5-6, 5-8, 5-9
IP Alias, 1-2
IP Alias Setup, 3-7
IP Multicast, 3-3
IP Network Number, 3-1
IP Pool, 3-3
IP Static Route, 6-1, 6-2, 6-3

L

LAN Setup, 2-6, 2-11, 2-12, 3-4, 3-5
log, 9-5
Log Facility, 9-7

M

MAC Address, 2-11, 14-2
Main Menu, 2-6
Metric, 5-6, 5-8, 5-10, 6-3
multiple servers, 4-3
My WAN Address, 5-8, 5-9

N

nailed-up connection, 5-4
Network Address Translation (SUA), 13-1
Network Address Translator (NAT), 4-2

P

Packet Triggered, 9-7
Packing List Card, xxiv
PAP, 5-2
password, 2-4
Password, 2-4, 2-7, 8-2

Ping, 9-12
Power Adapter, 2-3
PPP log, 9-7
PPPoE Encapsulation, 3-8, 3-11, 5-1, 5-4, 5-5, 5-9, 5-11
PPTP Encapsulation, 3-10, 5-1, 5-3, 5-7, 5-10
Private, 3-2, 5-7, 5-8, 5-10, 6-3, Q
Private IP Addresses, 3-2

R

Read Me First, xxiv
Rear Panel, 2-2
Related Documentation, xxiii
remote node, 5-1
Remote Node Filter, 5-10
Required fields, 2-5
Resetting the Prestige, 2-7
Restore Configuration, 10-4
RIP, 3-2, 3-6, 5-7, 5-8, 5-10

S

Safety Instructions, K
Safety Instructions, K
Server, 3-3, 3-6, 3-10, 5-2, 11-5, L, O, P
Service Type, 3-10, 5-2, 14-2
Single User Account, 4-1, 4-2
 Configuration, 4-2
SMT, 2-5
SNMP (Simple Network Management Protocol), 8-1
 Community, 8-3
 Configuration, 8-2
 Traps, 8-3
 Trusted Host, 8-3
Structure of this Manual, xxiii
SUA, 5-6, 5-8, 5-9
subnet mask, 3-2
Subnet mask, 3-6
Subnet Mask, 3-1, 3-10, 5-6, 5-8, 5-9, 6-3
Supporting CD, xxiii
sys stdio 0, 10-8
Syslog. *See* UNIX Syslog
Syslog IP Address, 9-7
System Information, 9-1, 9-4

System Maintenance, 2-7, 9-1, 9-2, 9-3, 9-4, 9-5, 9-6,
9-7, 9-11, 9-12, 10-1, 10-2, 10-3, 10-4, 10-5, 10-6,
11-1, 11-2, 11-3, 11-5
System Name, 2-9
System Status, 9-2
System Timeout, 13-2

T

TCP/IP, 3-1, 3-3, 3-4, 3-5, 3-6, 5-6, 5-9, 7-6, 7-7, 7-8,
7-10, 7-13, 7-17, 13-1, M, N, P
TCP/IP filter rule, 7-7
telnet, 13-1
Telnet Configuration, 13-1
Telnet Under SUA, 13-1
Terminal Emulation, 2-4
TFTP, 10-9
time and date setting, 1-2, 11-4
Time and Date Setting, 11-4, 11-5
Time Zone, 11-5
Timeout, 3-11, 3-12, 5-5
Trace, 9-5
Troubleshooting, 14-1
 Internet Access, 14-3
 LAN Interface, 14-2
 WAN Interface, 14-2

U

Unicast, 3-3
UNIX Syslog, 9-6, 9-7

Upload Firmware, 10-5
 Console Port, 10-6
 FTP, 10-6
 TFTP, 10-8
Upload Router Configuration File, 10-9
 FTP, 10-10
 TFTP, 10-11

V

VT100, 2-3

W

WAN DHCP, 9-11, 9-12
WAN Setup, 2-6, 2-10, 2-11, 14-2

X

xDSL modem, 1-3, 2-3, 2-4, 3-11, 5-4, 14-2, 14-3
XMODEM protocol, 10-2

Z

ZyNOS, 2-11, 9-3, 9-5, 10-1, 10-2
ZyNOS F/W Version, 9-3, 9-5, 10-1